

TM 11-5820-667-12

TECHNICAL MANUAL

**OPERATOR'S AND ORGANIZATIONAL
MAINTENANCE MANUAL**

**RADIO SET AN/PRC-77
(NSN 5820-00-930-3724)
(Including Receiver-Transmitter,
Radio RT-841 /PRC-77)
(NSN 5820-00-930-3725)**

This copy is a reprint which includes current pages from Changes 1 and 2.

This publication is required for official use or for administrative or operational purposes only. Distribution is limited to US Government Agencies. Other requests for this document must be referred to Commander, US Army Communications-Electronics Command and Fort Monmouth, ATTN: AMSEL-ME-P, Fort Monmouth, NJ 07703-5000.

**HEADQUARTERS, DEPARTMENT OF THE ARMY
1 JANUARY 1987**

Change
 No. 2

HEADQUARTERS
 DEPARTMENTS OF THE ARMY
 Washington, DC, 1 February 1991

**OPERATOR'S AND ORGANIZATIONAL MAINTENANCE MANUAL
 RADIO SET AN/PRC-77 (NSN 5820-00-930-3724)
 (INCLUDING RECEIVER-TRANSMITTER, RADIO RT-841/PRC-77) (NSN 5820-00-930-3725)**

TM 11-5820-667-12, 1 January 1989, is changed as follows:

1. The Navy and Air Force publication numbers, shown above, are added to the cover (not supplied).
2. Remove old pages and insert new pages as indicated below. New or changed material is indicated by a vertical bar in the margin of the page. Added or revised illustrations are indicated by a vertical bar adjacent to the identification number and by pointing hands on the illustration page.

<i>Remove page</i>	<i>Insert pages</i>
A and B	A and B
i and 1-0	i and 1-0
1-1 through 1-4	1-1 through 1-6
2-1 through 2-6	2-1 through 2-6
3-1 and 3-2	3-1 and 3-2
3-5 through 3-8	3-5 through 3-8
4-1 through 4-6	4-1 through 4-6
5-1 and 5-2	5-1 and 5-2
5-3 and 5-4	5-3, 5-3.1 / (5-3.2 blank) 5-4, 5-4.1 / (5-4.2 blank)
5-5/(5-6 blank)	5-5/(5-6 blank)
6-5 and 6-6	6-5 and 6-6
6-11 and 6-12	6-11 and 6-12
6-23 and 6-24	6-23 and 6-24
A-1 through A-3/(A-4 blank)	A-1 and A-2
B-7/(B-8 blank)	B-7/(B-8 blank)
C-1 and C-2	C-1 and C-2
D-1 and D-2	D-1 and D-2
E-1 and E-2	E-1 and E-2
I-1 and I-2	I-1 and I-2

3. File this change sheet in front of the publication for reference purposes.

Distribution authorized to the Department of Defense and DOD contractors only for official use or for administrative or operational purposes. This determination was made on 24 January 1991. Other requests for this document will be referred to Commander, US Army Communications-Electronics Command and Fort Monmouth, ATTN: AMSEL-LC-LM-LT, Fort Monmouth, NJ 07703-6000.

DESTRUCTION NOTICE - Destroy by any method that will prevent disclosure of contents or reconstruction of the document.

By Order of the Secretary of the Army•

CARL E. VUONO
General, United States Army
Chief of Staff

Official:

PATRICIA P. HICKERSON
Colonel, United States Army
The Adjutant General

By Order of the Secretary of the Navy:

JOHN C. WEAVER
Rear Admiral, United States Navy
Commander, Space and Naval Warfare
Systems Command

By Order of the Secretary of the Air Force:

LARRY D. WELSH
General, United States Air Force
Chief of Staff

Official:

CHARLES C. McDONALD
General, United States Air Force
Commander, Air Force
Logistics Command

DISTRIBUTION:

To be distributed in accordance with DA Form 12-51-E,
block 0898, Operator and Unit Maintenance requirements
for TM 11-5820-667-12.

CHANGE

No.1

HEADQUARTERS
DEPARTMENT OF THE ARMY
Washington, DC, 01 DECEMBER 1988

**OPERATORS AND ORGANIZATIONAL
MAINTENANCE MANUAL**

**RADIO SET AN/PRC-77
(NSN 5820-00-930-3724)
INCLUDING RECEIVER-TRANSMITTER
RT-841/PRC-77
(NSN 5820-00-930-3275)**

TM 11-5820-667-12, 1 January 1987, is changed as follows:

1. Remove old pages and insert new pages as indicated below. New or changed material is indicated by a vertical bar in the margin of the page. Added or revised illustrations are indicated by a vertical bar adjacent to the identification number.

<i>Remove pages</i>	<i>Insert pages</i>
I-3 through 1-6	1-3 through 1-6
2-3 and 2-4	2-3 through 2-4.1/(2-4.2 blank)
3-5 and 3-6	3-5 and 3-6
5-5/(5-6 blank)	5-5/(5-6 blank)
6-5 and 6-6.	6-5 and 6-6
D-1 and D-2.	D-1 and D-2

2. File this change sheet in the front of the publication for reference purposes,

Distribution authorized to the Department of Defense and DOD contractors only for official use or for administration or operational purposes. This determination was made on 7 July 1988. Other requests for this document will be referred to Commander, US Army Communications-Electronics Command and Fort Monmouth, ATTN: AMSEL-IC-ME-P, Fort Monmouth, NJ 07703-5000.

DESTRUCTION NOTIC-Destroy by any method that will prevent disclosure of contents or reconstruction of the document.

By Order of the Secretary of the Army:

Official:

CARL E. VUONO
General, United States Army
Chief of Staff

R.L. DILWORTH
Brigadier General, United States Army
The Adjutant General

DISTRIBUTION:

To be distributed in accordance with DA Form 12-51 Operator and
Unit requirements for AN/PRC-77.

WARNING

Adequate ventilation should be provided while using TRICHLOROTRIFLUOROETHANE. Avoid prolonged breathing of vapor. The solvent should not be used near heat or flame; the products of decomposition are toxic and irritating. Since TRICHLOROTRIFLUOROETHANE dissolves natural oils, avoid prolonged contact with skin. The use of chemical gloves (solvent resistant), chemical splash goggles and full faceshield are required when using TRICHLOROTRIFLUOROETHANE. DO NOT use compressed air to dry parts when TRICHLOROTRIFLUOROETHANE has been used. TRICHLOROTRIFLUOROETHANE is an ozone-depleting substance.

Lithium sulfur dioxide (Li-SO₂) batteries used with this equipment contain pressurized sulfur dioxide SO₂ gas. Sulfur dioxide gas is toxic; do not abuse the battery in any way which might cause it to rupture.

DO NOT heat, incinerate, short circuit, crush, puncture, mutilate or disassemble any battery.

DO NOT use any battery which shows signs of damage, such as bulging, swelling, disfigurement, swollen plastic wrap, liquid in the plastic wrap, etc.

IMMEDIATELY turn off the equipment if the battery compartment becomes hot to the touch. Let the battery cool at least 60 minutes before removing it. If you hear a hissing sound (battery venting) or smell irritating sulfur dioxide gas, remove the equipment to a well-ventilated area or leave the area.

DO NOT use equipment if the battery compartment shows signs of water leakage.

DO NOT use water to put out a fire if a shock hazard exists (i.e., 30 or more volts).

DO NOT use a HALON fire extinguisher on a lithium battery fire. Use an approved Class-D fire extinguisher such as Lith-X.

DO NOT test lithium batteries for capacity with Test Set, AN/PSM-13 and Connector, Adapter, U-410; this equipment is inaccurate for lithium batteries and may cause the battery to vent.

DO NOT recharge any primary lithium or magnesium battery.

DO NOT smoke or use an open flame in battery storage areas.

DO NOT dispose of lithium batteries in streams, rivers, oceans, with general refuse or trash, etc. Lithium batteries without a discharge switch shall be turned into the Defense Reutilization and Marketing Office (DRMO) for disposal. Dispose of magnesium batteries as generated; turn into DRMO only if damaged or quantity to be disposed of exceeds 500 pounds at one time. For additional information on battery disposal contact your local CECOM LAO/LAR for CECOM Safety Office Battery Disposition/Disposal Handbook dated November 1986.

DO NOT seal magnesium batteries in gas-tight plastic bags, drums or any other non-vented container. Depleted magnesium batteries continue to generate hydrogen gas after use, which can cause an explosion if it accumulates in a confined area.

DO NOT leave batteries in unused equipment more than 30 days. This helps insure that dangerous gases do not accumulate. Accumulated gases can cause explosions which can injure personnel and damage the equipment.

PREVENT personal injury when applying or removing steel strapping by wearing heavy gloves and a face shield. DO NOT handle packing cartons by steel strapping.

FIXED OPERATION WITH LONG RANGE ANTENNAS **WARNING**

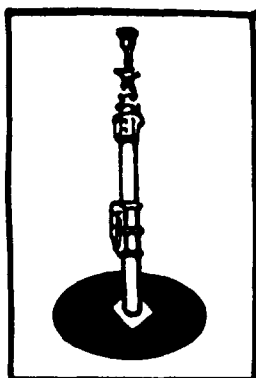

TELESCOPING ANTENNA
MAST

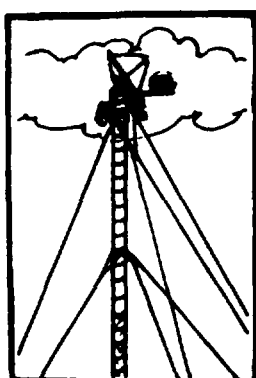

TYPICAL TOWER

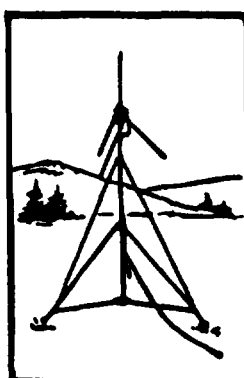

EXTENDED RANGE
ANTENNA

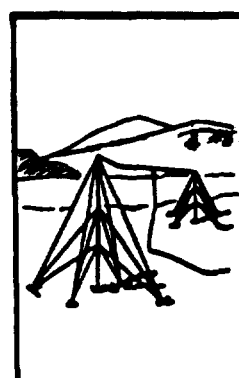

DOUBLET ANTENNA

NEVER ERECT THESE LONG RANGE ANTENNAS DIRECTLY UNDER POWER LINES.

IF YOU MUST ERECT THESE LONG RANGE ANTENNAS NEAR POWERLINES, POWERLINE POLES OR TOWERS, OR BUILDINGS WITH OVERHEAD POWERLINE CONNECTIONS, NEVER PUT THE ANTENNA CLOSER THAN TWO TIMES THE ANTENNA HEIGHT FROM THE BASE OF THE POWERLINE, POLE, TOWER OR BUILDINGS.

NEVER ATTEMPT TO ERECT ANY LONG RANGE ANTENNA WITHOUT A FULL TEAM.

BEFORE ERECTING ANY LONG RANGE ANTENNA, INSPECT ALL THE PARTS MAKING UP THE ANTENNA KIT. DO NOT ERECT THE ANTENNA IF ANY PARTS ARE MISSING OR DAMAGED.

DO AS MUCH OF THE ASSEMBLY WORK AS POSSIBLE ON THE GROUND.

WHEN ERECTING THE ANTENNA, ALLOW ONLY TEAM PERSONNEL IN THE ERECTION AREA.

MAKE SURE THAT THE AREA FOR THE ANCHORS IS FIRM. IF THE GROUND IS MARSHY OR SANDY, GET SPECIFIC INSTRUCTIONS FROM YOUR CREW CHIEF OR SUPERVISOR ON HOW TO REINFORCE THE ANCHORS.

WHEN SELECTING LOCATIONS FOR ANCHORS, AVOID TRAVELED AREAS AND ROADS. IF YOU CANNOT AVOID THESE AREAS, GET SPECIFIC INSTRUCTIONS FROM YOUR SUPERVISOR AS TO WHAT CLEARANCE YOUR GUY WIRES AND ROPES MUST HAVE OVER THE TRAVELED AREAS AND ROAD.

CLEARLY MARK ALL GUY WIRES AND ROPES WITH THE WARNING FLAGS OR SIGNS SUPPLIED BY YOUR UNIT. IN AN EMERGENCY, USE STRIPS OF WHITE CLOTH AS WARNING STREAMERS.

IF YOU SUSPECT THAT POWERLINES HAVE MADE ACCIDENTAL CONTACT WITH YOUR ANTENNA, STOP OPERATING, ROPE OFF THE ANTENNA AREA, AND NOTIFY YOUR SUPERIORS.

IF THE WEATHER IN YOUR AREA CAN CAUSE ICE TO FORM ON YOUR LONG RANGE ANTENNA AND ITS GUY WIRES AND ROPES, ADD EXTRA GUYS TO SUPPORT THE SYSTEM. ROPE OFF THE AREA AND POST IT WITH WARNING SIGNS LIKE "BEWARE OF FALLING ICE:"

DO NOT TRY TO ERECT ANY ANTENNA DURING AN ELECTRICAL STORM.

KEEP A SHARP EYE ON YOUR ANCHORS AND GUYS. CHECK THEM DAILY AND IMMEDIATELY BEFORE AND AFTER BAD WEATHER.



5

SAFETY STEPS TO FOLLOW IF SOMEONE IS THE VICTIM OF ELECTRICAL SHOCK

1

DO NOT TRY TO PULL OR GRAB THE INDIVIDUAL

2

IF POSSIBLE, TURN OFF THE ELECTRICAL POWER

3

IF YOU CANNOT TURN OFF THE ELECTRICAL POWER, PULL, PUSH, OR LIFT THE PERSON TO SAFETY USING A WOODEN POLE OR A ROPE OR SOME OTHER INSULATING MATERIAL

4

SEND FOR HELP AS SOON AS POSSIBLE

5

AFTER THE INJURED PERSON IS FREE OF CONTACT WITH THE SOURCE OF ELECTRICAL SHOCK, MOVE THE PERSON A SHORT DISTANCE AWAY AND IMMEDIATELY START ARTIFICIAL RESUSCITATION

TECHNICAL MANUAL 11-5820-667-12 }
 EE150-JN-MMO-01B/E154-PRC-77 }
 TO 31R2-2PRC77-1 }

HEADQUARTERS
 DEPARTMENTS OF THE ARMY
 Washington, DC, 1 January 1987

OPERATOR'S AND ORGANIZATIONAL MAINTENANCE MANUAL RADIO SET AN/PRC-77 (NSN 5820-00-930-3724) (INCLUDING RECEIVER-TRANSMITTER, RADIO RT-841/PRC-77) (NSN 5820-00-930-3725)

REPORTING ERRORS AND RECOMMENDING IMPROVEMENTS

You can help improve this manual. If you find any mistakes or if you know of a way to improve the procedures, please let us know. Mail your letter, DA Form 2028 (Recommended Changes to Publications and Blank Forms), or DA Form 2028-2 located in back of this manual direct to: Commander, US Army Communications-Electronics Command and Fort Monmouth, ATTN: AMSEL-LC-LM-LT, Fort Monmouth, New Jersey 07703-5000.

For Air Force, submit AFTO Form 22 (Technical Order System Publication Improvement Report and Reply) in accordance with paragraph 6-5, Section VI, T.O. 00-5-1. Forward direct to prime ALC/MST.

For Navy, mail comments to the Commander, Space and Naval Warfare Systems Command, ATTN: SPAWAR 8122, Washington, DC, 20363-5100.

In either case a reply will be furnished direct to you.

	Paragraph	Page
CHAPTER 1. INTRODUCTION		
Section I. General	1-1	1-1
II. Description and data	1-9	1-2
CHAPTER 2. INSTALLATION		2-1
3. OPERATING INSTRUCTIONS		3-1
4. OPERATOR'S MAINTENANCE INSTRUCTIONS		
Section I. Preventive maintenance	4-1	4-1
II. Troubleshooting	4-4	4-5
CHAPTER 5. ORGANIZATIONAL MAINTENANCE		
Section I. General	5-1	5-1
II. Preventive maintenance	5-3	5-1
III. Troubleshooting	5-4	5-3
CHAPTER 6. MATERIEL USED IN CONJUNCTION WITH RADIO SET AN/PRC-77		6-1
APPENDIX A. REFERENCES		A-1
B. MAINTENANCE ALLOCATION		B-1
C. COMPONENTS OF END ITEM LIST		C-1
D. ADDITIONAL AUTHORIZATION LIST		D-1
E. EXPENDABLE SUPPLIES AND MATERIALS LIST		E-1
INDEX		I-1

*This manual supersedes TM 11-5820-667-12, June 1967, in its entirety.



EL3YR016

Figure 1-1. Radio Set AN/PRC-77 in Man-Pack Operation with 3-foot Antenna AT-892/PRC-25 Installed.

CHAPTER 1

INTRODUCTION

Section I. GENERAL

1-1. Scope

a. This manual describes Radio Set AN/PRC-77 and covers its installation, operation, and operator's and organizational maintenance.

b. Maintenance allocation for the radio set is provided in appendix B. A listing of components is provided in paragraph 1-6 and appendix C. Additional equipment authorized to operate the radio is listed in appendix D.

c. Repair parts for organizational maintenance are provided in TM 11-5820-667-20P. Expendable supplies used for maintaining the radio are listed in appendix E.

1-2. Consolidated Index of Army Publications and Blank Forms

Refer to the latest issue of DA Pam 25-30 to determine whether there are new editions, changes, or additional publications pertaining to the equipment.

1-3. Maintenance Forms, Records, and Reports

a. *Reports of Maintenance and Unsatisfactory Equipment.* Department of the Army forms and procedures used for equipment maintenance will be those prescribed by DA Pam 738-750, as contained in Maintenance Management Update. Air Force personnel will use AFR 66-1 for maintenance reporting and TO-00-35D54 for unsatisfactory equipment reporting. Navy personnel will report maintenance performed utilizing the Maintenance Data Collection Subsystem (MDCS) IAW OPNAVINST 4790.2, Vol 3 and unsatisfactory material/conditions (UR submissions) IAW OPNAVINST 4790.2, Vol. 2, chapter 17.

b. *Reporting of Item and Packaging Discrepancies.* Fill out and forward SF 364 (Report of Discrepancy (ROD)) as prescribed in AR 735-11-2/DLAR 4140.55/SECNAVINST 4355.18/AFR 400-54/MCO 4430.3J.

c. *Transportation Discrepancy Report (TDR) (SF361).* Fill out and forward Transportation Discrepancy Report (TDR) (SF 361) as prescribed in AR 55-38/NAVSUPINST 4610.33C/AFR 75-18/MCO P4610.19D/DLAR4500.15.

1-4. Reporting Equipment Improvement Recommendations (EIR)

a. *Army.* If your AN/PRC-77 needs improvement, let us know. Send us an EIR. You, the user, are the only one who can tell us what you don't like about your equipment. Let us know why you don't like the design or performance. Put in on an SF 368 (Product Quality Deficiency Report). Mail it to: Commander, US Army Communications-Electronics Command and Fort Monmouth, ATTN: AMSEL-ED-PH, Fort Monmouth, New Jersey 07703-5000. We'll send you a reply.

b. *Air Force.* Air Force personnel are encouraged to submit EIR's in accordance with AFR 900-4.

c. *Navy.* Navy personnel are encouraged to submit EIR's through their local Beneficial Suggestion Program.

1-5. Administrative Storage

Administrative storage of equipment issued to and used by Army activities will have preventive maintenance performed in accordance with the PMCS charts before storing. When removing the equipment from administrative storage, the PMCS should be performed to ensure operational readiness.

1-6. Destruction of Army Electronics Materiel

Destruction of Army electronics materiel to prevent enemy use shall be in accordance with TM 750-244-2.

1-7. Hand Receipt Technical Manual

A Hand Receipt Technical Manual, TM 11-5820-667-12-HR, is available. It contains preprinted DA Form 2062 (Hand Receipt/Annex No.) listing the AN/PRC-77 parts as given in section II of appendix C. The Hand Receipt manual is

published to aid property accountability and is available through: Commander, US Army Adjutant General Publications Center, 2800 Eastern Blvd., Baltimore, MD 21220 in accordance with the procedures in Chapter 3, AR 310-2 and DA Pam 310-10. The Hand Receipt Technical Manual is entitled: Hand Receipt Manual Covering End Item/Components of End Item (COEI), Basic Issue Items (BLL), and Additional Authorization List (AAL) Related to Radio Set AN/PRC-77.

Section II. DESCRIPTION AND DATA

1-8. Purpose and Use. (fig. 1-1)

a. Radio Set AN/PRC-77 is a man-pack, portable, frequency-modulated (fm) receiver-transmitter used to provide short-range, two-way, radio-telephone voice communication.

b. Receiver-Transmitter, Radio RT-841/PRC-77 is also used as part of Radio Sets, AN/VRC-64 and AN/GRC-160 (TM 11-5820-498-12).

c. Fm radio sets with which the AN/PRC-77 can communicate are listed in paragraph 3-11 (fig. 3-3).

d. The AN/PRC-77 can also be used in conjunction with other equipment, (1) through (7) below.

(1) Antenna Equipment RC-292 (TM 11-5820-348-15) and Antenna Group OE-254/GRC (TM 11-5985-357-13) can be used in place of the whip antennas to extend the communication range of the AN/PRC-77 (para 6-3).

(2) The AN/PRC-77 can be connected to other fm radio sets for radio relay use by means of the cable in Retransmission Cable Kit MK-456/GRC (TM 11-5995-202-15 and para 6-1). Such radios can be the AN/PRC-77, AN/PRC-25 (TM 11-5820-398-12); the vehicular versions of these radios: Radio Sets AN/VRC-53, AN/VRC-64, AN/GRC-125, and AN/GRC-160 (TM 11-5820-498-12); and the AN/VRC-12 series radios (TM 11-5820-401-10 and TM 11-5820-401-20).

(3) Remote control of the AN/PRC-77 can be provided by Radio Set Control Group AN/GRA-39(*) (para 6-7a) and Radio Set Control AN/GRA-6 (para 6-9a).

(4) Radio/wire integration (RWI) operation with the AN/PRC-77 and remote telephone

facilities can be provided by Radio Set Control AN/GSA-7 with Oscillator O-574/GRA (para 6-8). The AN/GRA-39(*) (para 6-7b) and AN/GRA-6 (para 6-9b) can also be used with the AN/PRC-77 for RWI operation.

(5) The AN/PRC-77 can be used with Antenna, Homing Loop AT-784/PRC (para 6-4) for detection and location of homing beacons or other fm radios.

(6) The AN/PRC-77 can be used with Antenna AT-984A/G (para 6-5), a long-wire, multiple wavelength antenna to extend the transmission and reception ranges.

(7) The RT-841/PRC-77 maybe carried on a person's back using Pack Frame LC-2 (fig. 1-2 and 2-5; para 6-10). The LC-2 is one configuration of a pack frame used for existence loads by ground troops.

1-9. Technical Characteristics

Frequency range:
 Low band 30.00 to 52.95 MHz ±3.5 kHz.
 High band 53.00 to 75.95 MHz ±3.5 kHz.
 Number of channels. . . 920.
 Channel spacing 50 kHz.
 Types of transmission and reception:
 Transmission Voice (300 to 3,500 Hz) and 150 Hz squelch tone.
 Reception Voice (no squelch) or voice and 150 Hz squelch tone.
 Security or digital data equipment. . . Wideband (10 to 20,000 Hz) without 150 Hz squelch tone.

Transmission and reception				
power requirements:				
Transmission	12.5 to 15 vdc,	780 ma average.		
Reception	12.5 to 115vdc,	60MA average.		
Type of modulation	Frequency.			
Transmitter output				
power	1.0 to 4.0 W			
Type of squelch	Tone operated by 150 Hz signal.			
Distance range	5 mi (8 km) (varies with conditions).			
Type of antennas:				
Short Antenna	Antenna AT-892/PRC-25; 3 ft long, semirigid steel tape.			
Long antenna	Antenna AT-271A/PRC; 10 ft long, multisection whip.			
Power source	Battery, Dry BA-5598/U, BA-4386/U or BB-586/U rechargeable type Ni/Cd			
Battery life	As follows (with a 9:1 receive-transmit ratio):			
Battery	Hr at 70-130°F	Hr at 0°F	Hr at -40°F	Hr at -60°F
BA-4386/U	65	18	0	0
BA-5598/U	65	42	30	25
BB-586/U	35	20	0	0

1-10. Items Comprising Operable Equipment (fig. 1-2)

A quantity of one each component is provided with the AN/PRC-77. Dimensions and weights of components are provided in paragraph 2-1b. A battery is required to operate the RT-841/PRC-77 (para 1-13). See appendix C for listing of AN/PRC-77 components including National stock numbers.

1-11. General Description (fig. 1-2)

Radio Set AN/PRC-77 consists of Receiver-Transmitter, Radio RT-841/PRC-77 and minor components. The RT-841/PRC-77 is described in *a* below; the minor components in *b* below.

a. Receiver-Transmitter, Radio RT-841/PRC-77. The RT-841/PRC-77 consists of the receiver-transmitter, the receiver-transmitter case, and Battery Box CY-2562/PRC-25.

(1) The receiver-transmitter is held in the receiver-transmitter case by four captive screws. The CY-2562/PRC-25 is attached to the receiver-transmitter case by two clamps. The complete RT-841/PRC-77, when

assembled, is watertight. All controls are located on the front panel. A battery connector projects from the receiver-transmitter and mates with the connector of the battery.

(2) The CY-2562/PRC is a light-weight metal case that protects and houses the battery. The battery sits on foam pads that are attached to the bottom of the CY-2562/PRC-25.

(3) A pressure relief valve (fig. 2-3) is installed in CY-2562/PRC-25 to vent hydrogen gas (a by-product of the magnesium battery, BA-4386/U, discharge action) from the CY-2562/PRC-25 and thus prevent the gas from accumulating in the receiver/transmitter case and exploding. The valve is provided on new equipment and installed in used equipment per modification work order (MWO) 11-5800-211-30-1 (13 September 1972). The valve is required to prevent injury to personnel and prevent serious damage to the RT-841/PRC-77.

b. Minor Components (fig. 1-2).

(1) *Antenna AT-892/PRC-25.* The AT-892/PRC-25 is a one-section, 3-foot long whip antenna. A spring at its base allows for positioning of the antenna to keep it in a vertical position, regardless of the position of the RT-841/PRC-77. This antenna is used for general short-range service and, because of its steel tape construction, can be folded into a small space.

(2) *Antenna AT-271A/PRC.* The AT-271A/PRC is composed of seven sections; each section fits into the end of a wider section. A stainless-steel, plastic-covered cable (or braided plastic cord), under spring tension, is threaded through the sections to keep them together in the operating condition. When the sections are folded, the cable keeps them together as a group, to prevent the loss of individual sections. Spring tension is provided by a spiral spring in the base section. This antenna is used when maximum range is required.

(3) *Support, Antenna AB-591A/PRC.* The AB-591A/PRC, which is of rigid tubular construction, is used as a main support of the AT-271A/PRC.

(4) *Harness, Electrical Equipment LC-2.* The LC-2 is made of tubular aluminum with shoulder straps, a cargo support shelf and cargo tiedown straps. It secures the RT-841/PRC-77 so it can be carried on the operator's back.

(5) *Bag, Cotton Duck CW-503/PRC-25.* The CW-503/PRC-25 is sectionalized into several pockets which are used to store the two antennas, the antenna support, and handset ((6) below) (fig. 1-3).

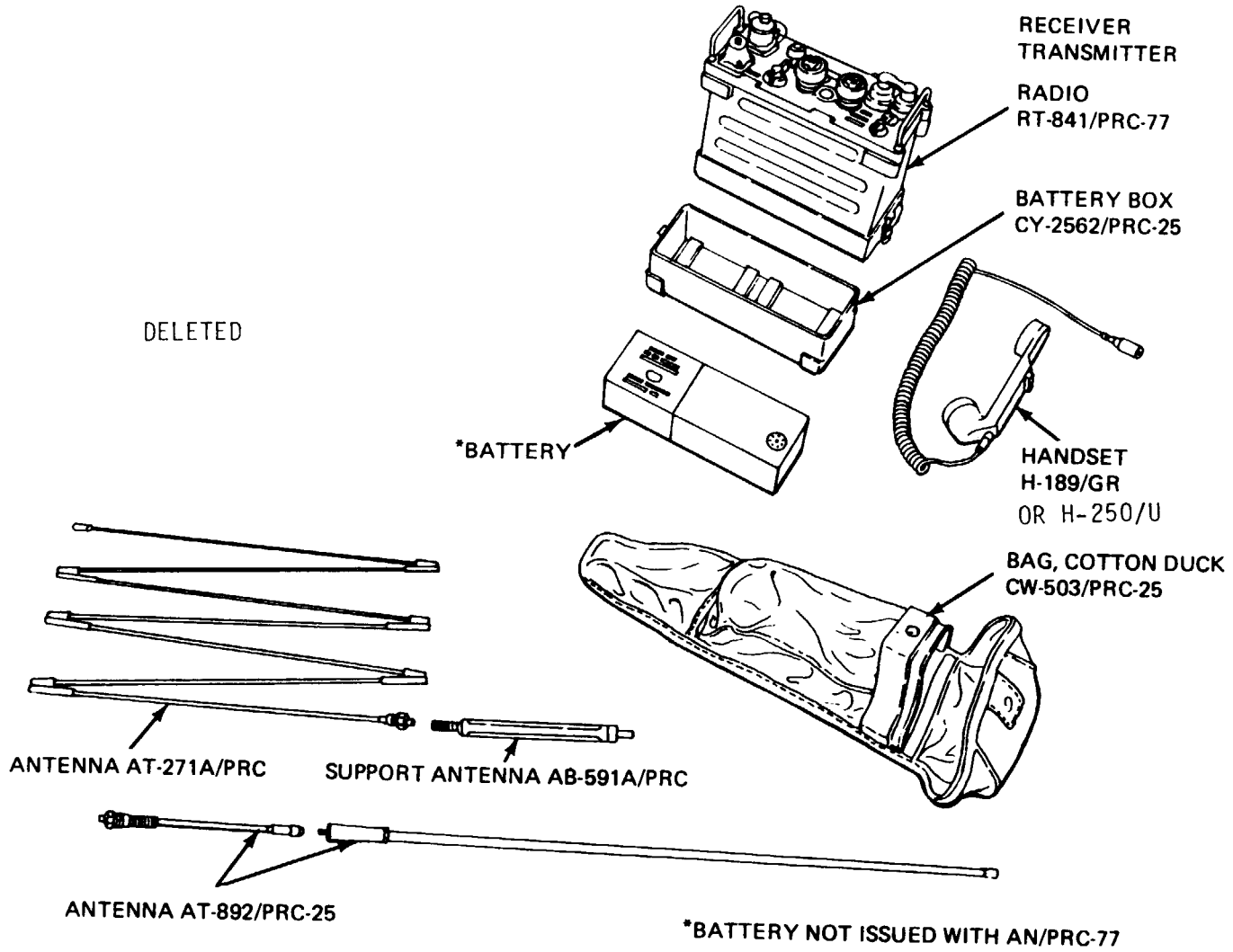
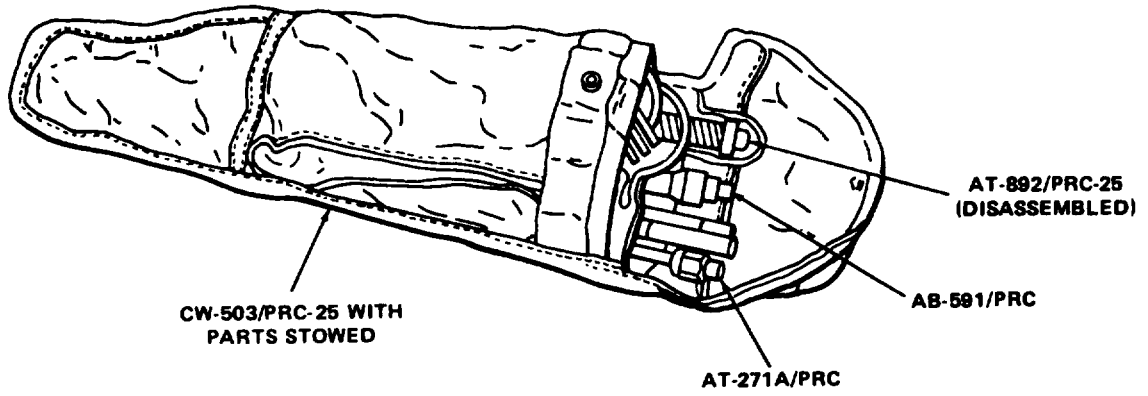

Figure 1-2. Radio Set AN/PRC-77, Components.

EL3YR017

HANDSET (AND SPARE BATTERY)



EL3YR018

Figure 1-3. Bag, Cotton Duck CW-503/PRC-25.

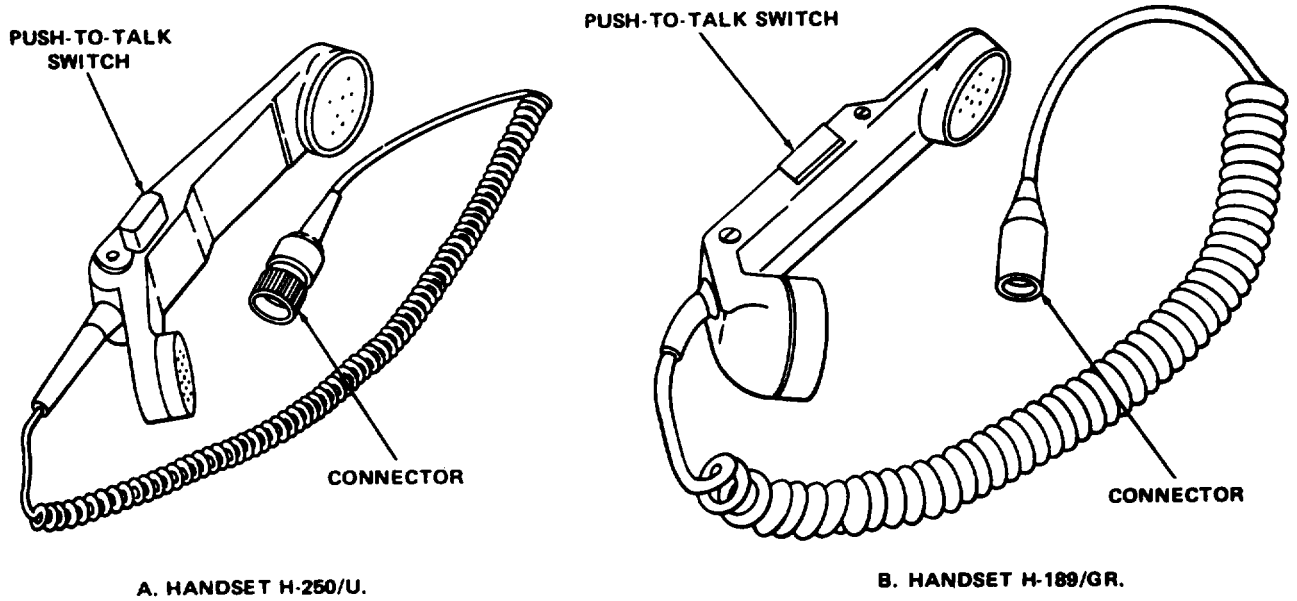

EL3YR019

Figure 1-4. Handsets H-189/GR and H-250/U.

(6) *Handset* (fig. 14). Either of the following handsets may be issued with the AN/PRC-77.

(a) *Handset H-189/GR*. The H-189/GR contains a dynamic microphone and receiver for transmitting and receiving signals. A push-to-talk switch is mounted in the handle. The connecting cord is retractile and terminates in a five-pin connector.

(b) *Handset H-250/U*. The H-250/U is similar to the H-189/GR except that it is lighter.

1-12. Additional Equipment Required

(fig. 2-2 and 2-3)

a. Batteries are not supplied with the AN/PRC-77, but are required for operation of the RT-841/PRC-77. Batteries are issued in accordance with requirements specified in SB 11-6.

(1) Battery, Dry BA-4386/U is a magnesium battery that has long life. The battery is provided with a female connector to mate with the battery connector on the RT-841/PRC-77. The battery supplies 3 and 15 volts; the 3-volt output is not used by the RT-841/PRC-77.

(2) Battery, Rechargeable BB-586/U is a rechargeable 12-volt Nickel-Cadmium Ni/Cd battery. When using the BB-586/U, Charger PP-7286/U is also required.

The BB-586/U can be recharged at least 200 times before disposal, and requires charging once every two weeks to maintain 85% of full capacity. The battery cannot operate at temperatures below -40F (-40C). When using the BB-586/U for power, two batteries are required—one in use and one being charged.

(3) Battery, Lithium BA-5598/U has longer life than Battery, Dry BA-4386, but is half its size. It may only be used for arctic/cold weather operation, conditions where the unique characteristics of the BA-5598/U are needed to accomplish the mission, and in equipment which cannot use any other battery. Two batteries BA-5598/U are required.

NOTE

When using lithium battery BA-5598/U, install one battery with its receptacle mating with the radio connector and a second battery placed in the battery box to take up room and secure the battery. Be sure two additional rubber pads have been added to the battery box to prevent movement of the batteries.

b. Use battery, Lithium BA-5598/U for arctic operation; see paragraph 6-2 for details.

CHAPTER 2

INSTALLATION

2-1. Unpacking (fig. 2-1)

a. *Packaging Data.* When packed for shipment, the components of the AN/PRC-77 are placed in an inner carton. A moisture-vaporproof barrier is placed around the inner carton. This package is placed in an outer carton. The outer carton is covered with a second moisture-vaporproof barrier and placed in a wooden packing box. The wooden packing box is 17 inches deep, 13 inches wide, and 9¾ inches high. The weight of the packed equipment is 20 pounds.

b. *Component Dimensions.* See table 2-1.

c. *Removing Contents.*

WARNING

Prevent personal injury when applying or removing steel strapping by wearing heavy gloves and a face shield. Do not handle packing cartons by steel strapping.

NOTE

When unpacking equipment that is packed only in cartons, omit procedures given in (1) through (8) below.

(1) Cut and fold back the metal straps.

CAUTION

Do not pry off boards. Prying may damage equipment.

(2) Remove nails from top and one side of wooden packing box with nailpuller.

(3) Open moisture-vaporproof barrier covering outer carton.

(4) Open outer carton. Open second moisture-vaporproof barrier covering inner carton.

(5) Remove and open inner carton.

(6) Remove corrugated filler.

(7) Remove and open envelope that contains technical manuals.

(8) Remove major and minor components.

2-2. Checking Unpacked Equipment

a. Inspect the equipment for possible damage incurred during shipment. If the equipment has been damaged, report the damage on Form SF 364 (para 1-3).

b. Check to see that the equipment is complete as listed on the packing slip. If the packing slip is not available, check the equipment against the components list (appx C). Report shortages on SF 361 per AR 735-11-2. Shortage of a minor assembly or part that does not affect proper functioning of the equipment should not prevent use of the equipment.

Table 2-1. Component Dimensions

<i>Component</i>	Overall dimensions (in.)			Volume (cu in.)	Weight (lb)
	Height	Width	Depth		
Receiver-Transmitter, Radio RT-841/ PRC.77	4	11	11	484	13.00
Battery Box CY-2562/PRC-25	4	3	11	132	0.75
Support, Antenna AB-591A/PRC	9	0.75	0.75	50	0.75
Antenna AT-892/PRC-25 (folded)	18.5	1	1.5	28	0.50
Antenna AT-271A/PRC (folded)	17	0.75	0.75	9	0.75
Harness, Electrical Equipment LC-2	19	6	5	520	3.00
Bag, Cotton Duck CW-503/PRC-25	19	4	6	456	0.75
Handset (H-189/GR or H-250/U)	8	2	3	48	1.20

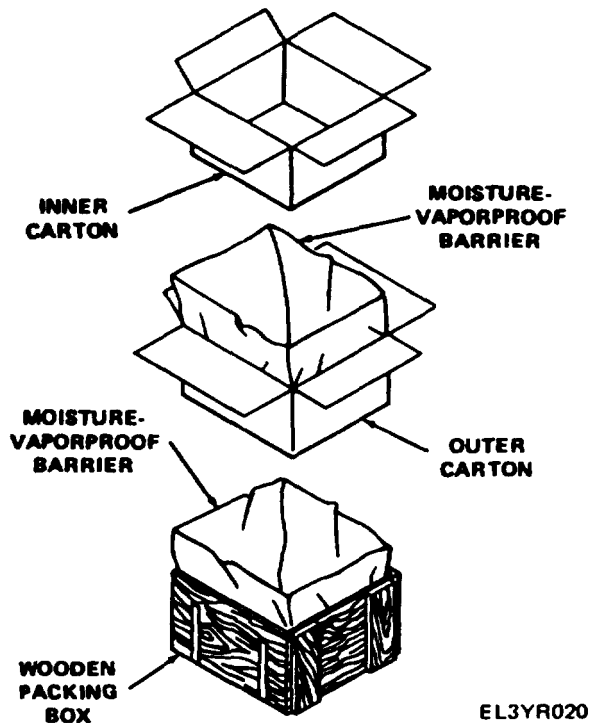
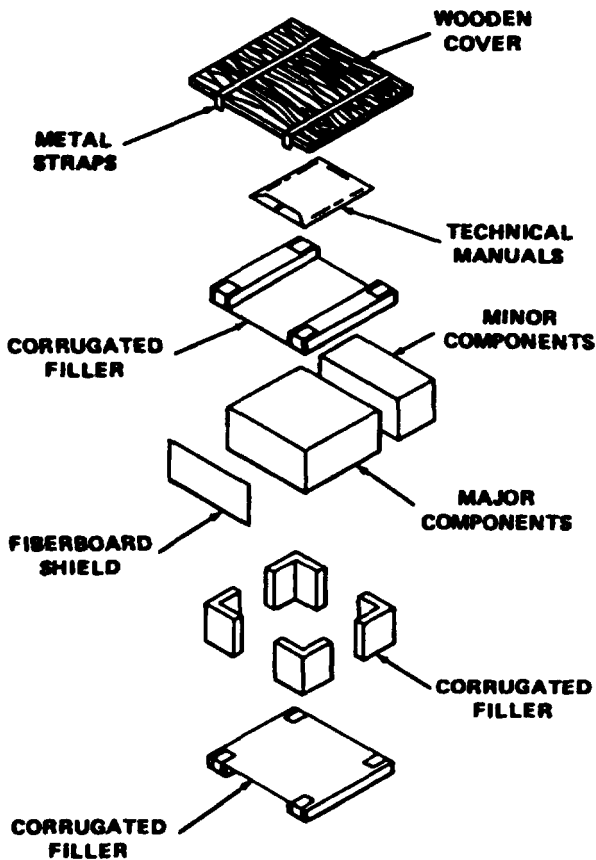

Figure 2-1. Typical Packaging.

c. If the equipment has been used or reconditioned, check to see if it has been changed by an MWO. If the equipment has been modified, the MWO number will appear on the front panel, near the nomenclature plate. Check to see if the MWO number (if any) and appropriate notations concerning the modification have been entered in the equipment manual. Current MWO'S applicable to the equipment are listed in DA Pam 25-30.

2-3. Siting

The AN/PRC-77 operates at low power and on high frequencies; therefore, the location of the equipment greatly affects its operating range (distance). Normally, a line-of-sight range can be expected; that is, if the other Station can be seen, satisfactory operation improbable. An intervening hill or a tall building may hamper or prevent contact with other stations. Valleys, densely wooded areas, and low places are poor sites. Location on a hilltop or a tower will increase operating distance. If possible, avoid locations near a source of electrical interference, such as power or telephone lines, radar sets, and field hospitals.

2-4. Installation and Removal of Battery (fig. 2-2 and 2-3)

NOTE

When using the new BA-5598/U lithium batteries, be sure two additional rubber pads have been added to the battery box to prevent movement of batteries.

- a. Stand the RT-841/PRC-77 on a level surface with its front panel facing downward.
- b. Release the two clamps by pushing the top-most part of each clamp down and away from the receiver-transmitter case.
- c. Remove the CY-2562/PRC-25 and remove the battery.
- d. Inspect the radio connector; if it is damaged or loose, the receiver-transmitter must be repaired. If the pressure test screw is not sealed with epoxy (item 4, appx E), tighten and seal it. Tighten the pressure relief valve.
- e. Position the new battery so that the radio connectors mate and, when installing a magnesium battery, the guide pin on the battery mates with the guide pin bushing.
- f. If Battery, Lithium BA-5598/U is used, install a spare BA-5598/U to take up the remaining room and secure the other battery.
- g. Install the CY-2562/PRC-25 on the receiver-transmitter case and tighten the two clamps.

WARNING

Lithium sulfur dioxide (Li-SO₂) batteries used with this equipment contain pressurized sulfur dioxide (SO₂) gas. Sulfur dioxide gas is toxic; do not abuse the battery in any way which might cause it to rupture.

DO NOT heat, incinerate, short circuit, crush, puncture, mutilate or disassemble any battery.

DO NOT use any battery which shows signs of damage, such as bulging, swelling, disfigurement, swollen plastic wrap, liquid in the plastic wrap, etc.

IMMEDIATELY turn off the equipment if the battery compartment becomes hot to the touch. Let the battery cool at least 60 minutes before removing it. If you hear a hissing sound (battery venting) or smell irritating sulfur dioxide gas, remove the equipment to a well-ventilated area or leave the area. Report any battery venting or incident to your local safety office and the CECOM Safety Office, AMSEL-SF-REE within 24 hours. Hold the battery and equipment for further analysis. Forward any questions on battery safety to Commander, U.S. Army Communications-Electronics Command and Fort Monmouth, ATTN: AMSEL-SF-REE, Fort Monmouth, New Jersey 07703-5000.

DO NOT use equipment if the battery compartment shows signs of water leakage.

DO NOT use water to put out a fire if a shock hazard exists (i.e., 30 or more volts).

DO NOT use a HALON fire extinguisher on a lithium battery fire. Extinguish fires in areas near batteries with water or a carbon dioxide fire extinguisher. If lithium batteries are involved, use an approved Class-D fire extinguisher such as Lith-X.

DO NOT test lithium batteries for capacity with Test Set, AN/PSM-13 and Connector, Adapter, U-410; this equipment is inaccurate for lithium batteries and may cause the battery to vent.

DO NOT recharge any primary lithium or magnesium battery.

DO NOT smoke or use an open flame in battery storage areas.

DO NOT dispose of lithium batteries in streams, rivers, oceans, with general refuse or trash, etc. Lithium batteries without a discharge switch shall be turned into the Defense Reutilization and Marketing Office (DRMO) for disposal. Dispose of magnesium batteries as generated; turn into DRMO only if damaged or quantity to be disposed of exceeds 500 pounds at one time. For additional information on battery disposal contact your local CECOM LAO/LAR for CECOM Safety Office Battery Disposition/Disposal Handbook dated November 1986.

DO NOT seal magnesium batteries in gas-tight plastic bags, tires or any other non-vented container. Depleted magnesium batteries continue to generate hydrogen gas after use, which can cause an explosion if it accumulates in a confined area.

2-4.1. Battery Storage**NOTE**

You can distinguish between Magnesium Battery BA-4386/U or Nickel-Cadmium Battery BB-586/U and Lithium Battery BA-5598/U by their size. Lithium Battery BA-5598/U is half the size of the other batteries.

a. Coordinate battery storage areas with the local Fire Department (FD).

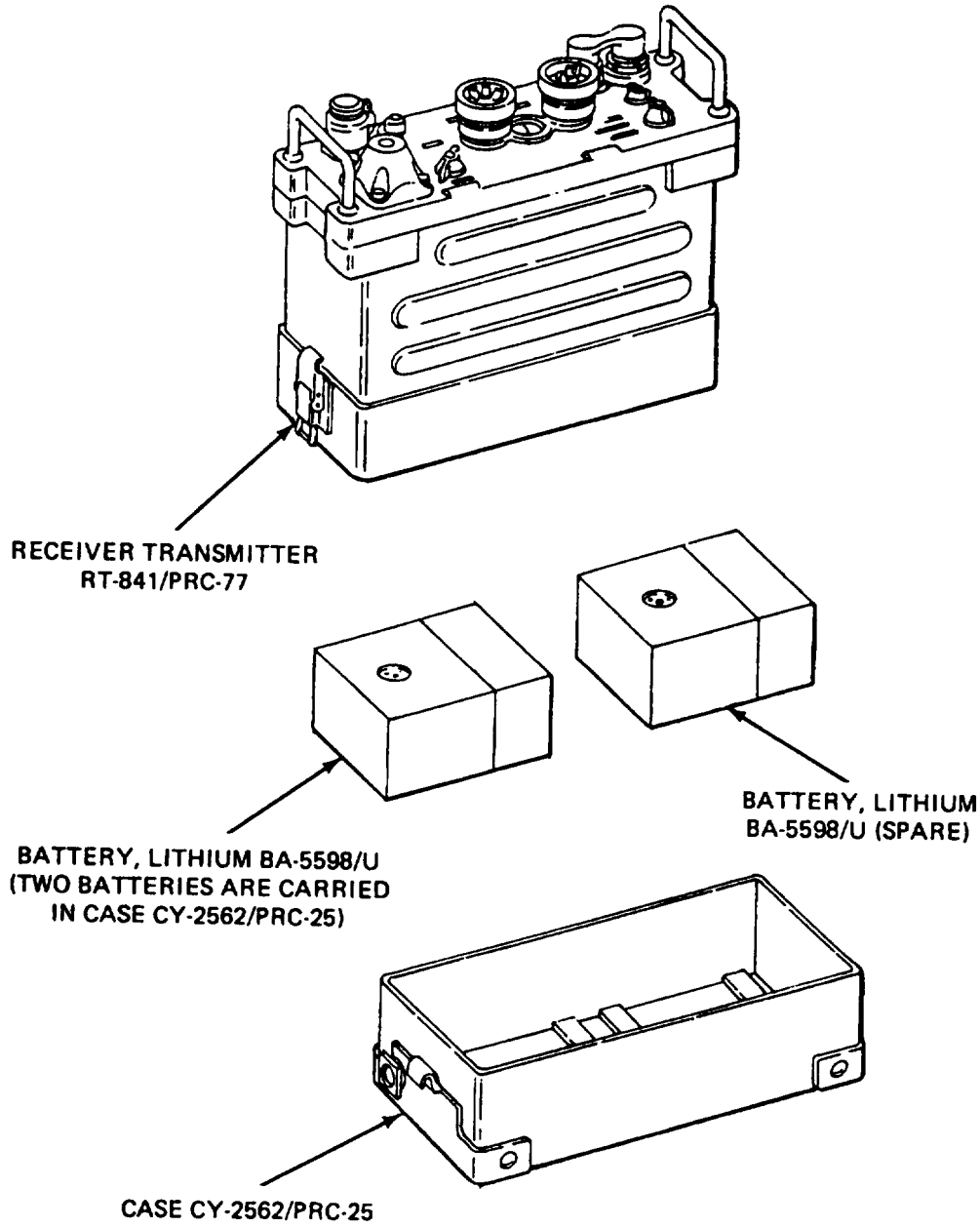

EL3YR015

Figure 2-2. Installation of Battery, Lithium BA-5598/U.

b. Store all batteries in a cool (under 130 degrees Fahrenheit), dry, well-ventilated area. Store them separately from combustible or other hazardous materials, with clearance space on all sides if possible.

c. Magnesium Battery BA-4386/U and Nickel-Cadmium Battery BB-586/U may be refrigerated; Lithium Battery BA-5598/U should not be refrigerated.

d. Use batteries from stock on a first-in first-out basis.

2-4.2. Battery Use

NOTE

Use only the batteries authorized for your equipment.

- a. Store batteries in their original packaging until ready for use.
- b. Check the batteries before installation for obvious defects.
- c. Inspect the radio battery compartment before and after use for water leakage and repair as necessary to keep the compartment watertight.
- d. Replace damaged, defective and inoperative batteries according to the instructions given in the WARNINGS sections above.
- e. Check Magnesium Battery BA-4386/U power using Battery Test Set AN/PSM-13 with Connector, Adapter U-410. When using Nickel-Cadmium Battery BB-586/U, refer to TM 11-6140-231-14 for testing requirements.

WARNING

DO NOT test Lithium Battery BA-5598/U with Test Set AN/PSM-13 and Connector, Adapter U-410; this equipment is inaccurate for lithium batteries and may cause the battery to vent.

- f. Perform the procedures given in paragraph 5-8 quarterly to minimize leakage of explosive hydrogen gas into the radio compartment.

2-5. Assembly and Installation for Man-Pack Operation

- a. Attach the LC-2 (fig. 2-4) to the receiver-transmitter as instructed in (1) through (4) below.

NOTE

Install the battery in the receiver-transmitter (para 2-4) before proceeding.

(1) Place the LC-2 flat on a level surface with the cargo shelf facing up.

(2) Place the receiver-transmitter on the LC-2 with its front panel toward the top and the CY-2562/PRC-25 resting on the cargo shelf of the LC-2.

(3) Fasten the RT-841/PRC-77 to the LC-2 with the two cargo tiedown straps. Hook the metal end of the strap into the buckle. Then feed the cloth end through the center slot on the buckle, then down through the end slot. Tighten strap, then snap down buckle to secure.

(4) Clip the CW-503/PRC-25 (cotton bag) to the upper cargo tiedown strap.

b. Mount the LC-2 on the operator as follows (fig. 2-5).

(1) Install the desired antenna (para 2-6).

(2) Connect the H-189/GR (handset) to one of the AUDIO connectors on the front panel of the RT-841/PRC-77.

(3) Place the LC-2, with the RT-841/PRC-77 attached, on the operator's back. Place the shoulder straps over the operator's shoulders.

(4) Hook the quick-release buckle on each shoulder strap and snap down the cover strap on each.

(5) Fasten the waist straps.

2-6. Installation of Antennas

Use the long, 10-foot AT-271A/PRC when maximum range is required. Use the short, 3-foot AT-892/PRC-25 when maximum range is not required.

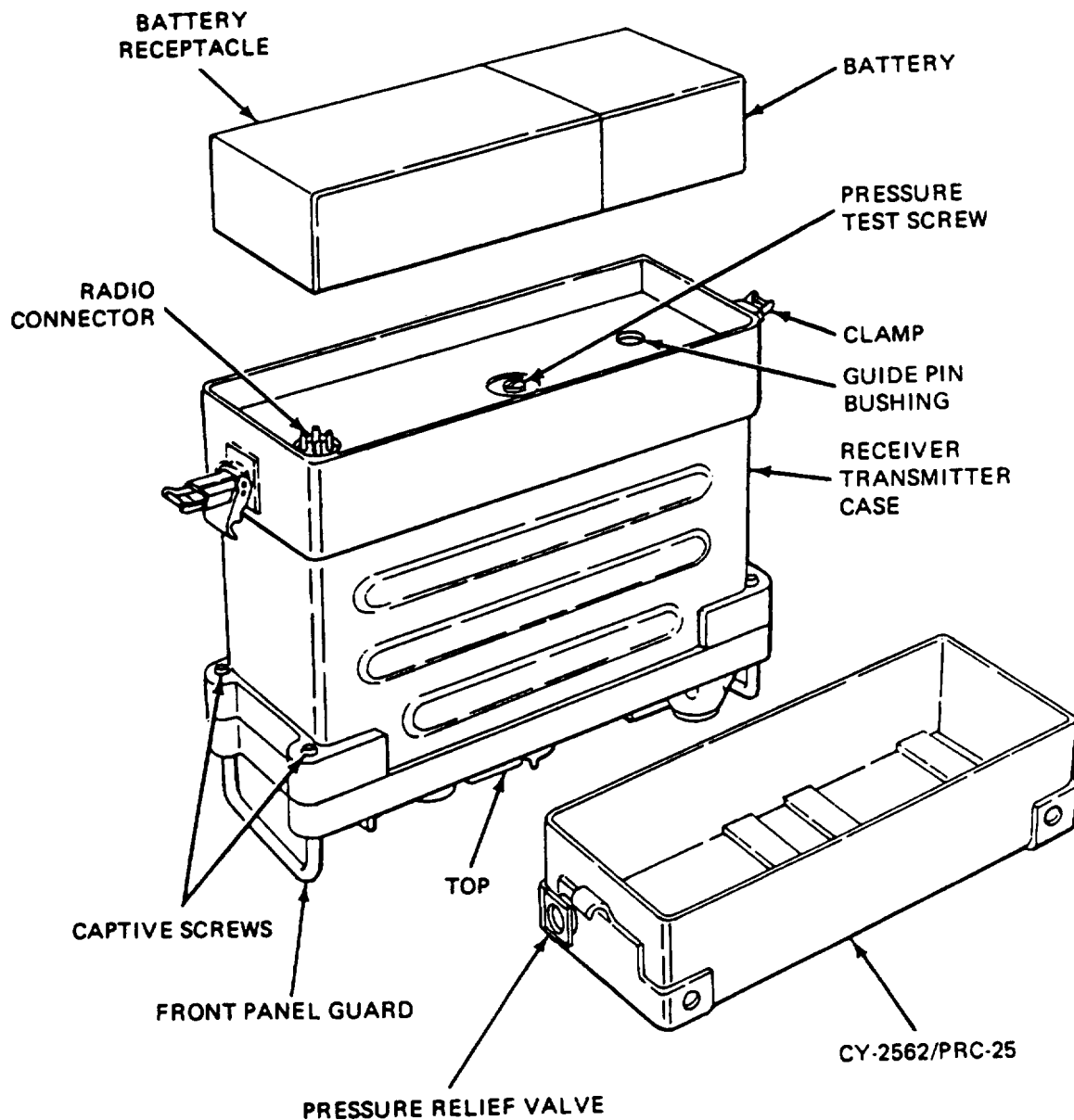

EL3YR021

Figure 2-3. Installation of Battery, Magnesium BA-4386/U.

CAUTION

If as little as 1/16-inch gap is allowed between the top of the whip antenna receptacle and the flat bottom of the antenna, the antenna may break at this point, leaving the threaded portion in the antenna receptacle. A plastic

filling has been included among the threads but it may become worn and ineffective in preventing the antenna from unscrewing due to vibration. To safeguard the antenna, periodically tighten it in the antenna receptacle.

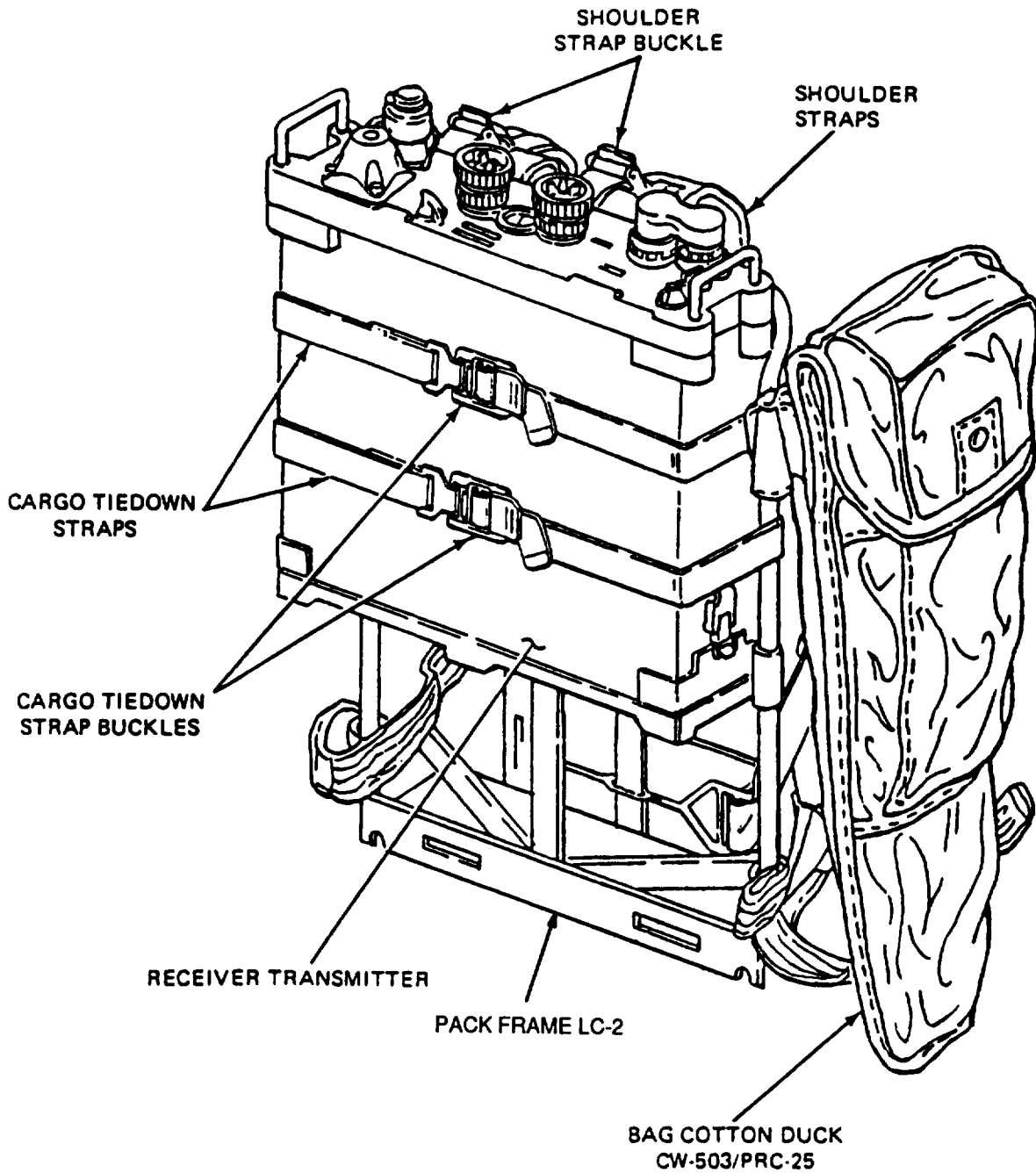

EL3YR022

Figure 2-4. Installation of Receiver-Transmitter in LC-2.

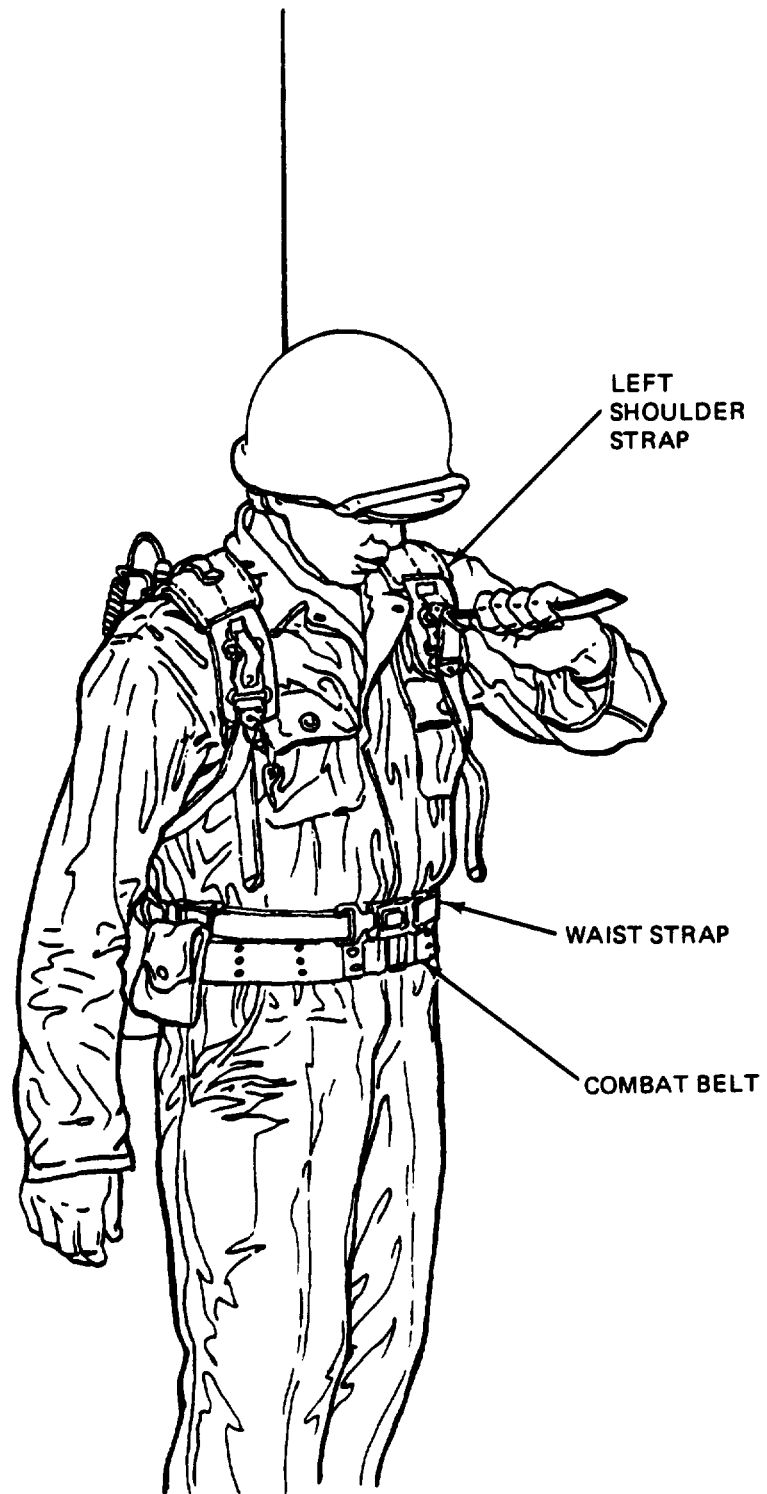

EL3YR023

Figure 2-5. Installing AN/PRC-77 for Man-Pack Operation.

a. Antenna AT-271A/PRC.

(1) Check to see that the tip is securely screwed to the top element and that the threaded stud at the other end is securely screwed to the bottom element.

(2) Remove the cover from the whip ANT receptacle.

(3) Screw Support, Antenna AB-591/PRC-25 into the whip ANT receptacle.

(4) Extend the AT-271A/PRC by holding the base section (the heaviest section) and carefully whipping it outward. If all sections are not secure, repeat this procedure, or insert the sections individually by hand.

(5) Screw the extended AT-271A/PRC into the AB-591/PRC-25.

b. Antenna AT-892/PRC-25.

(1) Remove the cover from the whip ANT receptacle.

(2) Screw the blade section securely to the spring base section. Screw the spring base section securely to the whip ANT receptacle.

NOTE

When folding the AT-892/PRC-25, always fold the blade section toward the concave (curved in) side.

(3) The AT-892/PRC-25 spring base section permits positioning of the antenna at any angle other than vertical to the top of the receiver-transmitter. For best communication, the antenna should be vertical to the ground (A and B, fig. 2-6). When the operator or the transmitter is in a position other than vertical to the ground, the antenna should be adjusted so that it is vertical to the ground. If the vertical position would reveal the operator's position, the antenna can be positioned so that it is horizontal to the ground (C, fig. 2-6). Under this situation, the direction of communication is broadside to the antenna.

c. Other Antennas.

(1) For long-distance operation, refer to paragraph 6-3 for information on Antenna Equipment RC-292 and Antenna Group OE-254/GRC.

(2) To detect other radio stations, refer to paragraph 6-4 for information on the use of Antenna, Homing Loop AT-784/PRC.

(3) To use a long-wire antenna, refer to paragraph 6-5 for information on Antenna AT-984A/G.

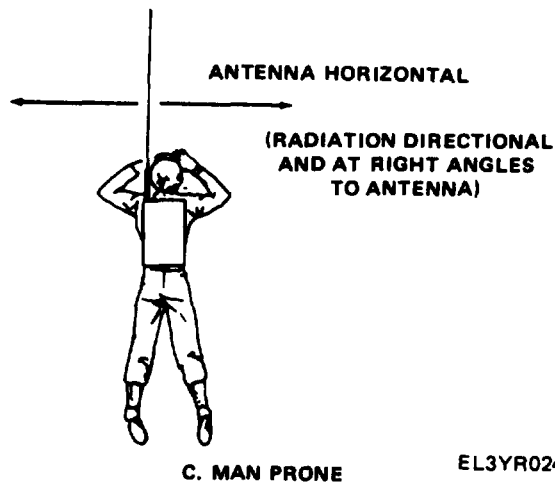
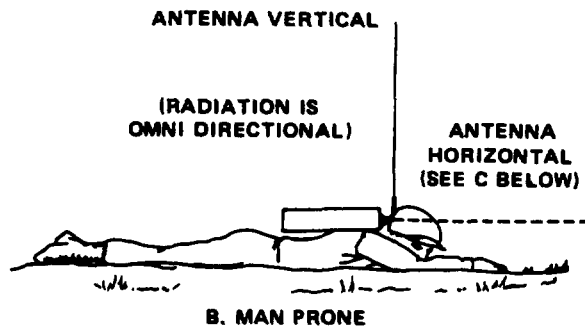

EL3YR024

Figure 2-6. Orientation of AT-892/PRC-25 in Various Positions on User.

CHAPTER 3

OPERATING INSTRUCTIONS

CAUTION

Do NOT change the MHz and kHz tuning controls or the BAND switch while the radio is keyed for transmission (handset push-to-talk switch depressed). Damage to modules in the radio may result, or the wrong channel frequency may be set up, thus preventing radio communication.

Battery power should be between 12.5 and 15 volts dc, with plus (+) applied to the B terminal on the battery connector (at the back of the receiver-transmitter) and minus (-) applied to the A terminal. Do not interchange these battery polarities; to do so will result in damage to modules in the radio.

3-1. Receiver-Transmitter, Radio RT-841/PRC-77, Controls, Indicators, and Connectors (fig. 3-1)

See table 3-1 for controls, indicators and connectors for Receiver-Transmitter, Radio RT-841/PRC-77.

3-2. Presetting Channel Frequencies (fig. 3-1 and 3-2)

On the MHz and kHz controls (fig. 3-1) are pre-set levers that can be set to catch the stops on each control (fig. 3-2). Thus, when two channels are preset, they can be selected without

Table 3-1. Receiver-Transmitter, Radio RT-841/PRC-77 Controls, Indicators, and Connectors

Control, Indicator or Connector	Sw Position	Function	Action
Function switch	OFF	Turin off Power.	
	ON.	Applies power.	
	SQUELCH	Applies power and stops rushing noise when no signal is received.	
	RETRANS.	Permits radio relay operation.	
	LITE.	Spring-loaded position; lights channel dial.	
BAND switch	30-52.	Selects lower frequency band, A band.	
	53-75.	Selects higher frequency band, B band.	
MHz tuning control		Tunes radio in 1 MHz steps as indicated by channel dial.	
KHz tuning control		Tunes radio in 50 kHz steps as indicated by channel dial.	
REC-TRANS FREQUENCY dial		Indicates operating frequency in MHz and kHz,	
PRESET levers		Permit rapid location of two preset frequencies.	
VOLUME control		Varies receiver volume.	
AUDIO connectors		Provides connections for handset or retransmission cable.	
ANT mount*		Provides connection for Antenna AT-271A/PRC or AT-892/PRC-25.	
ANT connector*		Provides connection for fried ground-plane or vehicular antenna.	
POWER connector.		Provides connection for external power supply when RT-841/PRC-77 is used as part of vehicular radio set configurations. When RT-841/PRC-77 uses battery in CY-2562/PRC-25 (fig. 2-2 and 2-3), the radio will not operate if the cover for the power connectors is not in place.	

*Other antennas may be used. See paragraphs 6-3 and 6-4.

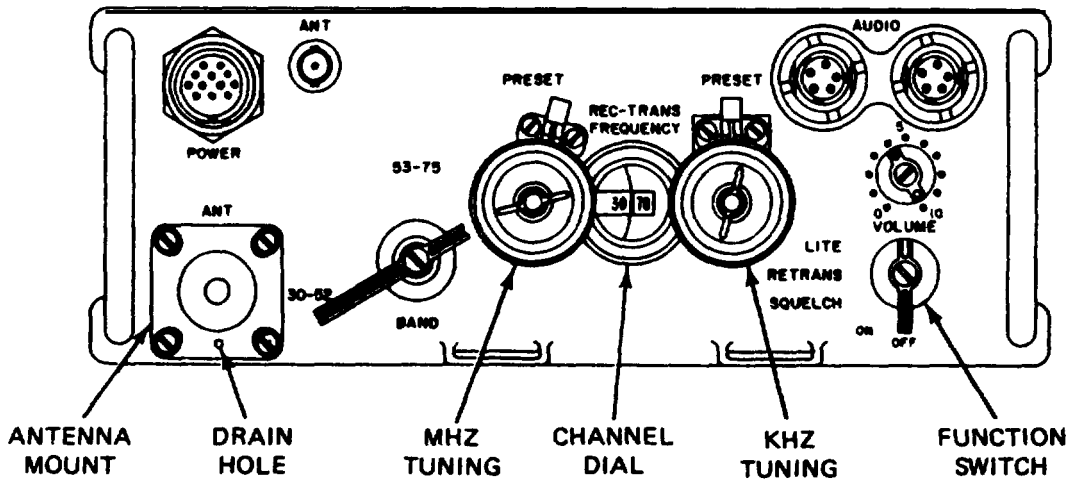

EL3YR025

Figure 3-1. Receiver-Transmitter, Radio RT-841/PRC-77, Controls, Indicators, and Connectors.

looking at the channel dial (fig. 3-1). Use the procedures in a below to set the kHz control; use the procedures in b or c below b set the MHz control.

NOTE

When presetting the controls, the two frequencies to be set must be considered the *lower* and the *higher* frequencies; and the sections of each tuning control as the *inner* (next to the front panel) and the *outer* sections (fig. 3-2).

a. *Presetting kHz Tuning Control.* Determine the lower and higher kHz frequencies. (For example: 35 in 59.35 MHz, 70 in 39.70 MHz, etc., with 35 as the lower frequency and 70 as the higher frequency.)

- (1) Set the preset lever away from the kHz control (A and B, fig. 3-2).
- (2) Set the kHz control so that the *lower* frequency appears in the channel dial.
- (3) Position the preset lever forward against the control (C, fig. 3-2) and loosen the wingnut on the control.
- (4) Pull up on the lower section of the control and turn it clockwise until the stop on the lower section strikes the preset lever. Tighten the wingnut
- (5) Position the preset lever away from the control.

(6) Turn the control until the higher frequency appears in the channel dial (both sections move).

(7) Loosen the wingnut and position the preset lever forward against the control.

(8) Without disturbing the setting of the lower section, pull on the upper section and turn it clockwise and align the stop with the preset lever.

(9) Keeping the upper section against the preset lever, tighten the wingnut.

(10) Check the settings for the lower and higher kHz frequency settings by turning the control counterclockwise to the stop for the lower kHz frequency, and clockwise to the stop for the higher kHz frequency.

(11) Set the MHz control (b below).

b. *Presetting MHz Tuning Control.* Determine the assigned lower and higher MHz frequencies. (For example: 59 in 59.35 MHz, 39 in 39.70 MHz, etc.).

(1) *Presetting MHz frequencies in same band.* The procedure for presetting the lower and upper sections of the MHz control for MHz frequencies *that are in the same band are the same as those given for the kHz control in a above.* That is, the lower MHz frequency in the band is set with the lower section of the control; and the higher MHz frequency in the same band is set with the upper section.

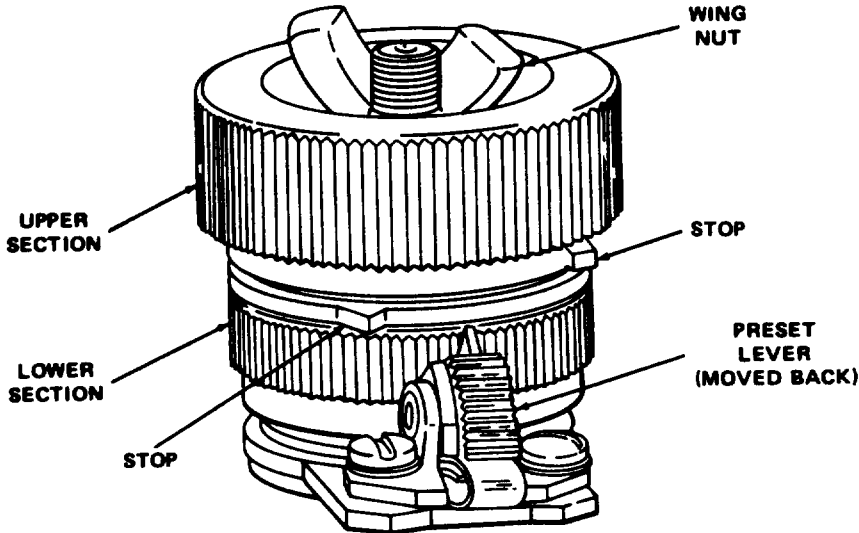

A. TUNING CONTROL; LOWER AND UPPER SECTIONS LIFTED.

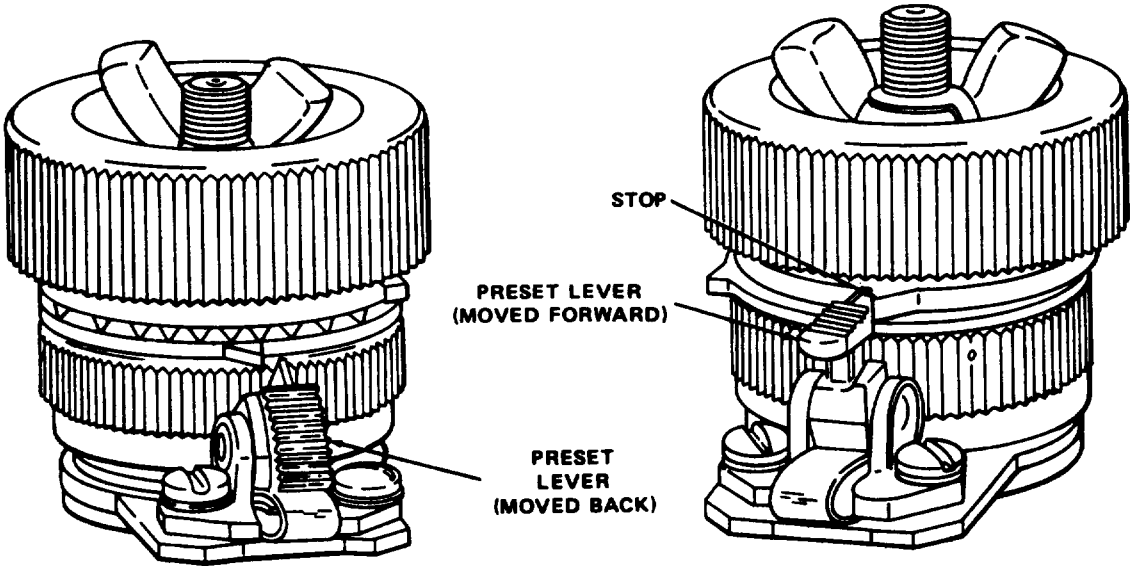

B. TUNING CONTROL; UPPER SECTION LIFTED.

C. TUNING CONTROL; STOP AGAINST PRESET LEVER.

EL3YR026

Figure 3-2. Presetting MHz and kHz Tuning Controls.

(2) *Presetting MHz frequencies in different hands.* Note that there are 23 positions of the control in each band: from 30 through 52 in band A; from 53 through 75 in band B.

(a) When presetting the MHz control for frequencies that are in *different* bands, always set the lower section to that MHz frequency that *is lower in its band* than the MHz frequency in the other band. *For example:* 54 is lower (second position) in band B than 33 MHz (fourth position) in band A; thus, 54 MHz would be set on the lower section and 33 MHz would be set on the upper section.

(b) To preset the MHz control sections, use the same procedures in *a* above with the band switch in the proper position and with the information given in *(a)* above.

3-3. Selecting Preset Channels (fig. 3-1 and 3-2)

To select a preset channel, proceed as follows:

a. Set the PRESET levers forward (toward the MHz and kHz tuning controls).

b. Set the BAND switch at 30-52 or 53-75, depending on the channel used.

c. Turn the MHz and kHz tuning controls until the stops strike against the PRESET levers.

d. Check the channel number that appears in the channel dial.

e. If the incorrect channel appears in the channel dial, turn the tuning controls against the stop in the opposite direction.

f. If the incorrect channel still appears, perform the presetting procedures as given in paragraph 3-2.

g. To select the other preset channel, turn the MHz and kHz tuning controls against the other stops. If the preset frequency is in the other band, set the BAND switch at the other position.

3-4. Operating Procedure (fig. 3-1)

NOTE

Do not change frequencies or the BAND switch while the radio is keyed (in transmit mode).

When using magnesium Battery BA-4386/U, wait approximately 1 to 2 minutes before transmitting (*e* below) to allow the battery to develop full power.

To obtain best operating range (distance), keep the whip antenna vertical to the ground. See figure 2-6 for various positions the operator can use to keep the short antenna vertical.

a. Set the function switch to ON. A rushing noise should be heard in the handset.

b. Set the BAND switch to 30-52 or 53-75 position, depending on the frequency being used.

c. Turn the MHz and kHz tuning controls to display the desired frequency in the channel dial. See the procedures in paragraph 3-3 to select preset channels.

d. Set the VOLUME control at 4; readjust for a desired sound level in the handset.

e. Transmit as follows:

(1) Press the push-to-talk switch on the handset.

(2) Speak into the handset.

NOTE

Do not speak into both elements of the H-138(*)/U. It has two microphone elements for noise cancellation; speaking into both elements simultaneously will cancel out your voice.

f. To receive, release the push-to-talk switch on the handset.

g. The receiver rushing noise can be eliminated by setting the function switch to SQUELCH during periods when the other station is not transmitting. Refer to paragraph 3-10 for squelch operation conditions. To determine whether squelch operation is possible, use the following procedures:

(1) Arrange for the distant station to send a short transmission while operating *without its squelch*.

(2) Set the function switch to ON; the rushing noise should be heard until the other station transmits.

(3) Arrange with the other station to turn its squelch switch to the ON position and to send a short transmission.

(4) On the RT-841/PRC-77 (receiver-transmitter), set the function switch to SQUELCH; the rushing noise should stop and the distant station should be heard when it transmits.

(5) If the other station cannot be heard now, reset the function switch to ON and advise the other station of the situation.

NOTE

The failure of either station to receive transmissions from the other may indicate one of the following:

The distance between the two stations is too great.

One of the other stations has not set the controls to transmit the 150 Hz squelch tone.

The squelch circuit of either radio station is defective.

Exercise the function switch by setting it in its various positions a few times.

(6) If either station is moving about, leave function switch in the ON position at both stations until it has been determined, by using the procedures in (1) through (5) above, that reception can be accomplished with the function switch at SQUELCH.

3-5. Stopping Procedure (fig. 1-2 and 1-3)

a. To turn off the receiver-transmitter, set the function switch to OFF.

b. If the AT-271A/PRC was used, disassemble it as follows:

CAUTION

When pulling out each section of the antenna, use only enough force to separate the sections, in order not to break the internal cord. Make sure each section has been separated from the next section before folding. Be sure to begin with the top section.

(1) Unscrew the AT-271A/PRC from the AB-591A/PRC (antenna support).

(2) Beginning with the top section, pull out each section from the next section and fold it along the side of the next lower section.

(3) Unscrew the AB-591A/PRC from the antenna mount.

c. Store the handset, both antennas, and the AB-591A/PRC in the CW-503/PRC-25 (cotton bag).

d. Close the flaps on the CW-503/PRC-25.

3-6. Recognition and Identification of Jamming

Under real or simulated tactical conditions, the receiver may be jammed by the enemy. Jamming is easily done by transmission of a stronger signal on the frequency being used, which makes it difficult or impossible to hear the desired signal. Unusual noises or strong interference heard on the receiver may be enemy jamming, signals from a friendly station, noise from a local source, or a defective receiver. To determine whether the interference is originating in the receiver, disconnect the antenna. If the interference continues, the receiver is defective.

3-7. Antijamming

When jamming of a channel is first noticed, notify your superior officer immediately and continue to operate the equipment. To provide maximum intelligibility of jammed signals, try the suggestions given in *a*, *b*, and *c* below.

a. The effects of enemy jamming may be reduced by placing the equipment so that nearby obstructions act as a screen in the direction of probable sites of enemy jamming transmitters. This screen action may also reduce the transmitted signal strength toward the enemy and thereby make it more difficult for him to intercept your signals. If possible, try several different locations within the designated area and stay at the one where jamming is minimum.

b. Vary the VOLUME control. The level of the desired signal may be raised enough to be distinguished from the jamming signal.

c. If the procedures in *a* and *b* above do not provide sufficient signal separation for operation, request change to an alternate frequency and call sign.

3-8. Operating Procedures Under Arctic Conditions

When operating the AN/PRC-77 under arctic conditions, use Lithium Battery BA-5598/U instead of Magnesium Battery BA-4386/U. Before operating in extreme cold, check to see that a coating of silicone grease has been applied to the neoprene rubber O-ring of the audio connectors.

3-9. Homing Operation

Use Antenna, Homing Loop AT-784/PRC (TM 11-5985-284-15) to provide the AN/PRC-77 with facilities for homing operation. Refer to paragraph 6-4 for operation of the AT-784/PRC with the AN/PRC-77.

3-10. Conditions for Squelch and Nonsquelch Operation

The explanations and squelch operating conditions in *a* through *d* below are applicable to the squelch operation in paragraph 3-4g.

a. When the function switch of the RT-841/PRC-77 is set to ON, a rushing noise is heard in the handset. The rushing noise stops when a second RT-841/PRC-77, or another transmitter operating on the same frequency, is keyed.

b. When the function switch is set to SQUELCH, no sound is heard in the handset until a second RT-841/PRC-77 or another transmitter operating on the same frequency, is keyed, provided the other transmitter transmits a 150 Hz squelch signal. Radios provided with this feature are given in *c* below. When the RT-841/PRC-77 is keyed for transmission with its function switch set to SQUELCH, a 150 Hz squelch signal is transmitted. This signal is heard as a sidetone buzz in the handset.

c. Communication with the function switch set to SQUELCH is possible when other stations in the radio net are using one of the following radio sets and if these radios also have their squelch switches in the ON positions. In general, when one of the following radio sets has its squelch switch set to the 150 Hz squelch function, the other radio sets in the net must be set similarly.

(1) Radio sets that are equipped with the RT-505/PRC-25, such as Radio Sets AN/PRC-25, AN/VRC-53, AN/VRC-54, and AN/GRC125.

(2) Radio sets that are equipped with the Receiver-Transmitter, Radio RT-841/PRC-77, such as Radio Sets AN/PRC-77, AN/VRC-64, and AN/GRC-160. The RT-841/PRC-77 looks like and operates identically to the RT-505/PRC-25.

(3) Radio sets that are equipped with the Receiver-Transmitter, Radios RT-246/VRC, RT-524/VRC, or Receiver Radio R-442/VRC, such as Radio Sets AN/VRC-12, and AN/VRC43 through AN/VRC-49, and AN/VRC-54. The 150 Hz squelch tone is transmitted from these radios when their squelch switch is set to NEW ON, NEW OFF, and OLD OFF. When the 150 Hz squelch signal is sent from another radio set, these radio sets will respond when their squelch switch is set to NEW ON.

(4) When communication is with Radio Sets AN/ARC-54 and AN/ARC-131, the squelch switch of these radio sets must be set to TONE.

d. To communicate with radio sets other than those listed in *c* above, the function switch of the RT-841/PRC-77 must be set to ON.

3-11. System Application (fig. 3-3)

Figure 3-3 shows various frequency-modulated (FM) radio sets with which the RT-841/PRC-77 can communicate within the 30-75.95-megahertz (MHz) band. Table 3-2 below lists the frequency ranges, the channel spacing of the radio sets, and their associated publications. All radios listed, except those in which preset crystals are required, can tune to any frequency within its operating range. Take note of the channel spacing in kilohertz. For example, communication with the Radio Set AN/PRC-6 can occur on 50.00 MHz, 50.20 MHz, 50.40 MHz, etc.

Table 3-2. Radio Set Frequency Ranges, Channel Spacings, and Publications

Radio Sets	Frequency Range (MHz)	Channel Spacings Every	Publication	Remarks
AN/PRC-77 ^a	30-75.95	50 kHz	TM 11-5820-667-12	
AN/VRC-53, AN/VRC-64, AN/GRC-125, AN/GRC-160 ^a	30-75.95	50 kHz	TM 11-5820-498-12	Includes AN/VRC-46, -24, and AN/PRC-25.
AN/VRC-54 ^a	30-75.95	50 kHz	TM 11-5820-401-20-1 -20-2	
AN/VRC-55 ^b	30-75.96	50 kHz	TM 11-5820-401-20-1 -20-2	
AN/VRC-49 ^a	30-75.95	50 kHz	TM 11-5820-401-20-1, -20-2	
AN/PRC-25 ^a	30-75.95	50 kHz	TM 11-5820-398-12	Channels provided by preset crystals.
AN/PRC-6	47-55.4	200 kHz	TM 11-296	
AN/PRC-9	30-38.90	100 kHz	TM 11-5820-292-10	
AN/PRC-10	38-54.9	100 kHz	TM 11-5820-292-10	
AN/PRC-28	30-42	100 kHz	TM 11-5820-292-10	
AN/PRC-68	30-79.95	50 kHz	TM 11-5820-882-10	
AN/ARC-44 (modified)	24-51.90	100 kHz	TM 11-5821-204-12	
AN/ARC-54 ^a	30-69.95	50 kHz	TM 11-6821-244-12	
AN/ARC-131 ^a	30-75.95	50 kHz	TM 11-5820-670-12	Includes AN/ARC-131.
AN/ARC-114 ^a	30-75.95	50 kHz	TM 11-5821-670-12	
AN/ASC-15 ^a	30-75.95	50 kHz	TM 11-5821-285-12	
Receiver-Transmitter RT-67/ GRC in:	27-38.90	100 kHz		
AN/GRC-5, AN/GRC-6			TM 11-284	
AN/VRQ-2			TM 11-287	
AN/VRC-9			TM 11-286	
AN/VRC-14			TM 11-291	
AN/VRC-17			TM 11-611	
AN/VRC-21			TM 11-642	
Receiver-Transmitter RT-68/ GRC in:	38-54.90	100 kHz		
AN/GRC-7, AN/GRC-8			TM 11-284	
AN/VRQ-3			TM 11-287	
AN/VRC-10			TM 11-286	
AN/VRC-15			TM 11-291	
AN/VRC-18			TM 11-611	
AN/VRC-22			TM 11-642	
Receiver-Transmitter RT-70/ GRC in:	47-58.40	100 kHz	TM 11-290	
AN/GRC-5 through AN/GRC-8			TM 11-284	
AN/VRC-7			TM 11-285	
AN/PRR-9	47-57	100 kHz	TM 11-5820-549-12	P/o squad radio; can only receive; preset crystals.
AN/PRT-4	47-57	100 kHz	TM 11-5820-549-12	P/o squad radio; can only transmit; preset crystals.

Table 3-2. Radio Set Frequency Ranges, Channel Spacings, and Publications — Continued

Radio Sets	Frequency Range (MHz)	Channel Spacings Every	Publication	Remarks
AN/PRT-4A ^a	47-57	100 kHz	TM 11-5820-549-12	P/o squad radio; can only transmit; preset crystals.
AN/GRC-163	30-75.95	50 kHz	TM 11-5820-713-15	Includes AN/VRC-47.
AN/TSC-61B ^b	30-75.95	50 kHz	TM 11-5895-469-15-1	
AN/TSQ-70A ^b	30-75.95	50 kHz	TM 11-5895-579-12	
AN/TSQ-71A ^b	30-75.95	50 kHz	TM 11-5895-474-12	
AN/FSQ-75(V) ^b	30-75.95	50 kHz	TM 11-5895-590-10	

^aThese radio sets have the 150 Hz squelch feature in their receiver-transmitters and receivers that make them compatible with the RT-841/PRC-77 for squelch operation. Refer to paragraph 3-10 for squelch details.

^bThese are radio configurations in which the AN/VRC-46 or AN/VRC-49 is a component.

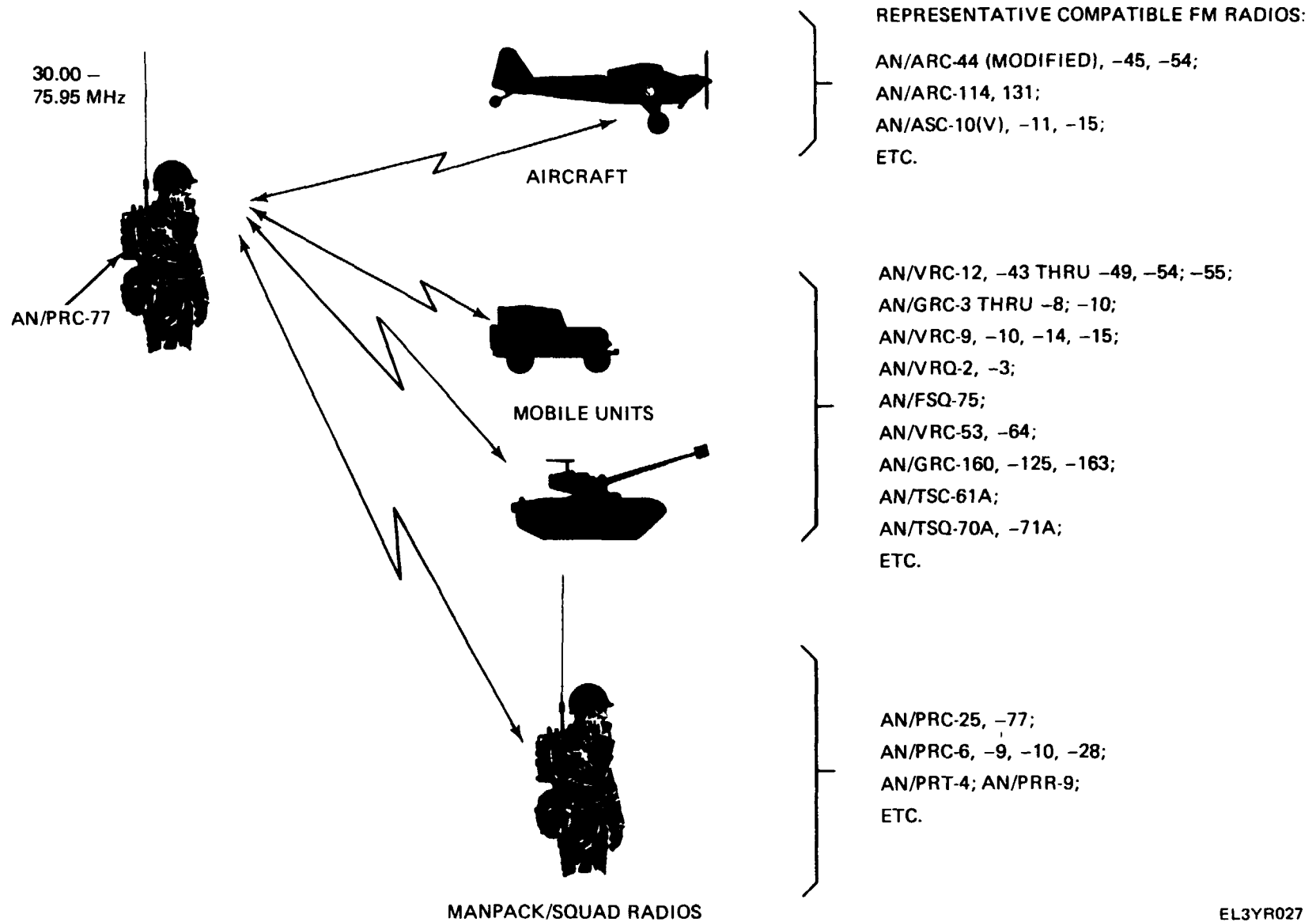

Figure 3-3. Typical Radio Systems Compatible with AN/PRC-77.

EL3YR027

CHAPTER 4

OPERATOR'S MAINTENANCE INSTRUCTIONS

Section I. PREVENTIVE MAINTENANCE

4-1. Scope of Operator's Maintenance

No special tools or test equipment are required for operator's maintenance of the AN/PRC-77. Trichlorotrifluoroethane (item 1, appx E) is required for cleaning (para 4-3). Operator's maintenance includes the following:

- a. Preventive maintenance (para 4-2, table 4-1).
- b. Replacing the battery (para 2-4).
- c. Troubleshooting (para 4-4 and 4-5).

4-2. Preventive Maintenance, General

Preventive maintenance is the systematic care, servicing, and inspection of equipment to prevent occurrence of trouble, and to ensure that the equipment is ready for use. Preventive maintenance checks and services (PMCS) defines procedures to be performed at specific intervals and under certain conditions (table 4-1).

- a. Before using the AN/PRC-77, verify that all components necessary for operation are on hand (appx C and D).
- b. Routine maintenance such as cleaning, dusting, washing, checking for frayed cables, loose nuts and bolts, loose switches, and controls, and damaged threads on threaded components, stowing items not in use, and covering unused receptacles, are not listed as PMCS procedures. These are things you should do anytime you see they must be done. If you find a routine check is in your PMCS, it was listed because other operators reported problems with this item.

c. Deleted.

d. Remove the battery (para 2-4) if the radio set will not be used again that day or for a longer period of time.

e. Before you operate perform your "before" (B) PMCS.

f. While you operate, perform your "during" (D) PMCS. The recording and reporting of your "during" (D) PMCS is done while performing the "after" (A) PMCS.

g. After you operate, perform your "after" (A) PMCS.

h. If the equipment was not used for a week, perform the (B), (D), and (A) PMCS together with the "weekly" (W) PMCS.

i. If the equipment must be kept in constant operation, check and service only those items that can be checked and serviced without disturbing operation. Make the complete checks and services when the equipment can be shut down.

j. If the equipment fails to operate, troubleshoot (para 4-4 and 4-5). If the equipment still fails to operate, submit it to higher category maintenance for repair using the proper forms (DA Pam 738-750).

k. The Item No. column in table 4-1 shall be used as a source of item numbers for the TM Item Number column on DA Form 2404 (Equipment Inspection and Maintenance Worksheet) in recording the results of the PMCS.

Table 4-1. Operator's/Crew Preventive Maintenance Checks and Services

NOTE

Within the designated interval, these checks are to be performed in the order listed.

B – BEFORE OPERATION D – DURING OPERATION A – AFTER OPERATION W – WEEKLY

Item No.	Interval				Item to be Inspected	Procedures Check and have repaired or adjusted as necessary.	For Readiness Reporting Equipment Is Not Ready/Available If:
	B	D	A	W			
1		•			Radio Set	<p>While operating the radio, check the following features:</p> <p>a. VOLUME control does not bind and there is no interruption of received signal as control is rotated through its range.</p> <p>b. Squelch operation is satisfactory (para 3-4g), if used.</p> <p>c. Communication is not intermittent.</p> <p>d. Under normal conditions (based on experience with antenna being used, terrain, distance to other radios, assigned operating frequencies, etc.), communication can be conducted.</p>	<p>b. Receiver rushing noise is not eliminated by transmission from/to a radio with squelch on.</p> <p>c. Transmission and/or reception is interrupted because of equipment failure.</p> <p>d. Communication cannot be conducted under normal conditions.</p>
2	•		•		Battery	<p>Check to see that the battery case (1) is not swollen (bulging), or leaking, and that the contact receptacle (2) is not damaged.</p> 	<p>Battery case is swollen (bulging) or leaking; contact receptacle is damaged.</p>
3				•	Antennas	<p>Check the following on the antenna being used:</p> <p>a. The spring section (2) is screwed down fully without a gap (3).</p> <p>b. The upper section (1) and spring section (2) can be screwed together fully.</p>	

Table 4-1. Operator's/Crew Preventive Maintenance Checks and Services - Continued

NOTE

Within the designated interval, these checks are to be performed in the order listed.

Item No.	Interval				Item to be Inspected	Procedures Check and have repaired or adjusted as necessary.	For Readiness Reporting Equipment Is Not Ready/Available If:
	B	D	A	W			
4					<ul style="list-style-type: none"> Handset 	<p>c. Sections of the long antenna are not damaged and the internal cord is not broken or frayed.</p>  <p>Perform the following:</p> <p>a. Check to see that:</p> <ol style="list-style-type: none"> Switch cover (rubber) (1) is in place and not cut. O-ring (3) is in place and is not loose in its groove. Handset connector locks firmly on radio connector (2). Case (4) is not cracked. Cord (5) is not cut or stretched out and wires are not exposed. <p>b. Clean connector (6) contacts (para 4-3d).</p> 	<p>c. Antenna sections are missing or cannot be assembled.</p> <p>a. Handset cannot be plugged into radio.</p>

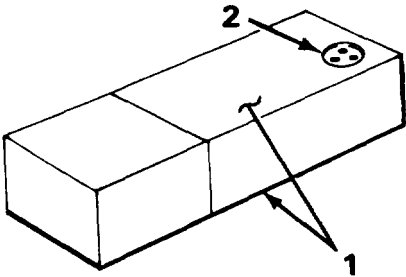
Table 4-1. Operator's/Crew Preventive Maintenance Checks and Services - Continued

NOTE

Within the designated interval, these checks are to be performed in the order listed.

B - BEFORE OPERATION D - DURING OPERATION A - AFTER OPERATION W - WEEKLY

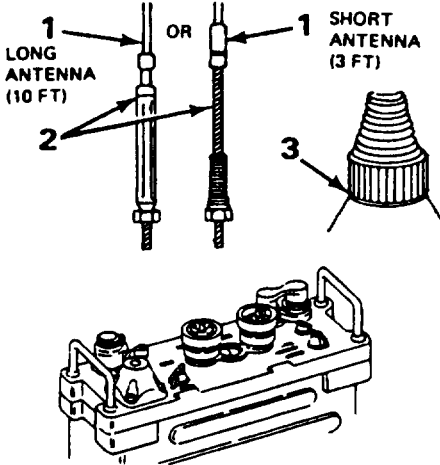
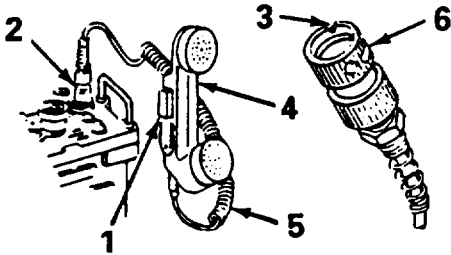
Item No.	Interval				Item to be Inspected	Procedures Check and have repaired or adjusted as necessary.	For Readiness Reporting Equipment Is Not Ready/Available If:
	B	D	A	W			
5				•	Battery Box	Perform the following: <i>a.</i> Tighten the pressure relief valve (1) if loose. <i>b.</i> Clean the inside (2) of the cover (para 4-3a and <i>b</i>). <i>c.</i> If there is evidence of leakage from the battery, replace the battery (item 2 above).	

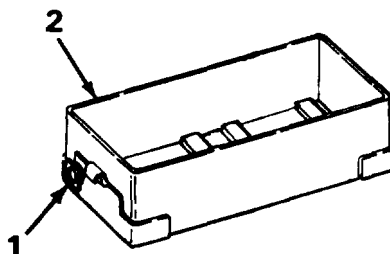

4-3. Cleaning

The surface of the equipment should be clean; that is, there should be no dirt, grease, oil, or fungus on the surfaces.

WARNING

The fumes of trichlorotrifluoroethane are poisonous. Provide adequate ventilation whenever you use trichlorotrifluoroethane. Do not use solvent near heat or open flame. Trichlorotrifluoroethane will not burn, but heat changes the gas into poisonous, irritating fumes. Do not breathe the fumes or vapors. Trichlorotrifluoroethane dissolves natural skin oils. Do not get the solvent on your skin. Use gloves, sleeves, and an

apron which the solvent cannot penetrate. If the solvent is taken internally, consult a physician immediately.

a. Remove dust and dirt with a clean cloth. If dirt is difficult to remove, dampen the cloth with water; soap may be used for more effective cleaning.

b. Remove grease, oil, fungus, and ground-in dirt with a cloth dampened (not wet) with trichlorotrifluoroethane.

c. Clean the canvas items (CW-503/PRC-25 and LC-2, fig. 2-3) with a brush moistened with trichlorotrifluoroethane.

d. Clean the contacts of the RT-841/PRC-77 AUDIO connector (fig. 3-1) and the handset connector (fig. 1-4) with a pencil eraser.

Section II. TROUBLESHOOTING

4-4. Visual Inspection

a. When the equipment fails in communication check the following items:

(1) Switches and controls are set correctly(para 3-4).

(2) The handset and antenna are secured to the receiver-transmitter.

b. If the above procedures do not clear the trouble, proceed to the troubleshooting chart (para 4-5).

4-5. Troubleshooting

Table 4-2 contains procedures an operator can follow to try to restore communication. Any trouble or equipment defect that cannot be corrected by the operator shall be referred to organizational maintenance.

CAUTION

Do not move the MHz and kHz tuning controls while the radio is keyed.

Table 4-2. Operator's/Crew Troubleshooting Procedures

Malfunction	Probable Cause	Corrective Action
1. Rushing noise is not heard when function switch is set to ON.	a. POWER connector is not tightened. b. Battery is defective (fig. 2-2 or 2-3).	a. Tighten POWER connector. b. Perform the following: (1) Set function switch to LITE; the dial lamp should light. (2) Key the receiver-transmitter and talk sidetone should be heard. (3) If neither of above indications is obtained, replace the battery (para 2-4) and repeat (1) and (2) above.
2. Rushing noise does not stop when function switch is set to SQUELCH.	a. Battery is very weak. b. Receiver-transmitter is defective.	a. Replace battery (para 2-4). b. Notify higher level of maintenance.
3. Communication cannot be conducted with distant radio set on assigned frequency; sidetone is heard during transmission.	a. Defective receiver-transmitter. b. Radio is located in poor location. c. The antenna is loose in its receptacle. d. The distance to the next radio terminal is too great for the short 3-foot Antenna AT-8924/PRC-25 (fig. 1-2).	a. Perform the following: (1) Rotate the MHz and kHz controls back and forth and change band switch a few times. (2) Try alternate frequencies. b. Move to another location; even a few feet may help. Set the antenna vertical. c. Screw the antenna down fully. d. Install the 10-foot Antenna AT-271A/PRC (para 2-6b).

Table 4-2. Operator's/Crew Troubleshooting Procedures-Continued.

Malfunction	Probable Cause	Corrective Action
<p>4. Communication in squelch mode cannot be established (para 3-4g) (function switch in SQUELCH position).</p>	<p>a. Distant radio is not compatible.</p> <p>b. Distant radio is compatible for squelch mode of operation.</p> <p>c. Radio is located in poor location.</p>	<p>a. If radio with which you are trying to communicate in squelch mode is not one of those identified in table 3-2, footnote <i>a</i> of the radios listed in paragraph 3-11, you must communicate without squelch by setting the function switch to ON.</p> <p>b. If the distant radio is using RT-246/VRC or RT-524/VRC, the SQUELCH switch can be set in any position except OLD ON. If another radio is being used, the 150 Hz squelch tone must be switched to ON.</p> <p>c. Move to another location; even a few feet may help.</p>
<p>5. Reception is normal, but no sidetone or intermittent sidetone or whistling or cracking noise is heard during transmission.</p>	<p>a. Audio connector contacts are dirty or corroded.</p> <p>b. O-ring is missing from handset connector.</p> <p>c. Handset or handset cable is defective.</p>	<p>a. Clean connector contacts, using a pencil eraser.</p> <p>b. Replace O-ring.</p> <p>c. Replace handset.</p>
<p>6. Communications cannot be conducted with distant radio but can be conducted with nearby radios (1/4 mile or less).</p>	<p>a. Antenna is defective.</p> <p>b. Audio connector contacts are dirty or corroded.</p> <p>c. Radio is in an extremely poor location.</p> <p>d. Battery is weak.</p> <p>e. Receiver-transmitter is defective.</p>	<p>a. Repair or replace antenna.</p> <p>b. Clean audio connector contacts, using a pencil eraser.</p> <p>c. Move radio to another location; even a few feet may help.</p> <p>d. Change battery.</p> <p>e. Rotate the MHz and kHz controls and change the band switch a few times.</p> <p style="text-align: center;">CAUTION</p> <p style="text-align: center;">Do not key the transmitter when changing the above controls.</p>
<p>7. Reception is satisfactory, but motorboating (loud buzzing) is heard during transmission.</p>	<p>Battery is defective.</p>	<p>Replace battery (para 2-4).</p>

CHAPTER 5

ORGANIZATIONAL MAINTENANCE

Section I. GENERAL

5-1. Scope or Organizational Maintenance

Organizational maintenance includes preventive maintenance (para 5-3 and table 5-1) and troubleshooting (para 5-4, 5-5, and 5-6).

5-2. Tools, Materials, and Test Equipment Required

a. Multimeter AN/URM-105 or Multimeter, Digital AN/PSM-45.

- b.* Tool Kit, Electronic Equipment TK-101/G.
- c.* Trichlorotrifluoroethane (item 2, appx E).
- d.* Silicone Compound (item 2, appx E).
- e.* Epoxy (item 4, appx E).
- f.* Polishing cloth.
- g.* Dow Corning No. 4 silicone grease (item 7, appx E).

Section II. PREVENTIVE MAINTENANCE

5-3. Organizational Preventive Maintenance Checks and Services, General

Preventive maintenance is the systematic care, inspection, and servicing of equipment to maintain it in serviceable condition, prevent breakdowns, and assure maximum operational capability. Organizational preventive maintenance checks and services (PMCS) are performed quarterly, in accordance with the procedures specified in this chapter, as indicated in table 5-1.

a. Some PMCS (*b* through *h* below) are routine and should be done any time you see they need to be done. Routine PMCS that are listed in the PMCS table are there because others have reported unusual or significant problems with a particular item.

b. Verify that the AN/PRC-77 is complete in accordance with appendices C and D.

CAUTION

Use only clear water and rag to clean plastic surfaces. Do not paint plastic surfaces

Damage to plastic will result if cleaned with solvents or painted.

c. Equipment should be kept free of dirt, grease, rust, fungus, and corrosion. Refer to paragraph 4-3 for routine cleaning procedures. Remove rust and corrosion from metal surfaces by lightly sanding with fine sandpaper and spot painting in accordance with SB 11-573 and TB 43-0118.

d. Check for loose, broken, or missing component control knobs, switches, and connectors. Verify that controls turn properly. Check plug-to-jack connections for proper orientation and tightness. Check for loose, bent, or missing connector pins. Verify that electrical connector covers are attached to the control panel and that each cover fits securely on its connector.

e. Inspect the battery connector to ensure that the radio connector gasket is undamaged and is seated flush with the bottom of the connector (inside the four mounting screws) and flush with the body of the connector; that the two O-rings on the radio connector are undamaged and are seated, under tension, in their grooves; and that the three radio connector pins are not loose, bent, or missing.

f. Check cables for fraying, cuts, cracks, or other damage.

- g. Check for loose mountings, hardware, brackets, etc.
- h. Using lung power, blow out all parts on both sides of the radio set case to get rid of gases that may have accumulated.

NOTE

Before performing the PMCS listed in table 5-1, verify that all current Modification

Work Orders (MWO's) for the specific radio-intercom system have been accomplished. DA Pam 25-30, Consolidated Index of Army Publications and Blank Forms (microfiche), contains a listing of current MWO'S for communications-electronics equipment

Table 5-1. Organizational Preventive Maintenance Checks and Services-Quarterly Schedule

Item No.	Item to Be Inspected	Procedure Check for and have repaired or adjusted as necessary.
1	Handset	<ul style="list-style-type: none"> a. Check to see that the O-ring in the cable connector is not loose or missing. b. Apply a thin coating of silicone compound (item 2, appx E) to the O-Ring (not to the connector contacts).
2	Receiver-Transmitter (fig. 2-3)	<ul style="list-style-type: none"> a. Check to see that the clamps are not damaged and hold the Battery Box securely to tie radio case. b. Check to see that the pressure test screw is in place and epoxy (item 4, appx E) is applied over the edge of the screw. c. Observe the case to see if there is any evidence of bulging (due possibly to gas exploding inside the case (para 1-11a(3))). d. Check to see that the dial locks function to lock and release the MHz and kHz controls (fig. 3-1). e. Clean out the whip antenna receptacle in the antenna mount (fig. 3-1). Clean out the small drain hole near the base of this antenna mount leading to the threaded antenna receptacle. f. Loosen the front panel captive screws (fig. 2-3), separate the front panel and chassis from the case, and perform the following checks: <ul style="list-style-type: none"> (1) Inspect battery connector for missing or damaged gasket, O-rings, and connector pins (para 5-3e). Apply a thin coat of silicone compound (item 2, appx E) to O-rings. (2) Inspect the gasket behind the front panel. If it is damaged or not flush with the case, have gasket replaced. Apply a thin coat of silicone compound (item 2, appx E) to gasket. (3) Reinstall the chassis in the case; tighten the four captive screws. There should be no gap or space between the edges of the case and the front panel chassis.
3	Battery Box (fig. 2-3)	<ul style="list-style-type: none"> a. Tighten the pressure relief valve, which must be installed (para 1-11a(3)). b. Apply light air pressure to both sides of the pressure relief valve; air should not go through the valve when applied from the outside of the case and should when applied from inside the case.
4	Antenna, AT-892/PRC-25 (fig. 1-2)	<ul style="list-style-type: none"> a. Check to see that the bottom section holds the upper section firmly in position when the upper section is bent at various angles. b. Apply a thin coat of silicone compound (Item 2, appx E) to the threaded connector.
5	Antenna Base (fig. 1-2)	<ul style="list-style-type: none"> a. Check to see that the unit is not damaged or distorted. b. Clean out the threaded receptacle and apply a thin coat of silicone compound (item 2, appx E) to the threads on both ends of the unit.

Table 5-1. Organizational Preventive Maintenance Checks and Services-Quarterly Schedule - Continued

Item No.	Item to Be Inspected	Procedure Check for and have repaired or adjusted as necessary.
6	Antenna, AT-271A/PRC	<p>a. Check to see that the cord running through the sections is not broken and that there is no water in the sections.</p> <p>b. Check to see that each section fits into the next section, when fully extended and assembled.</p> <p>c. Check to see that the tip cap is in place.</p> <p>d. Check to see that the threaded connector is securely attached to the bottom section.</p> <p>e. Apply a thin coat of silicone compound (item 2, appx E) to the threaded connectors.</p>
7	LC-2 (fig. 1-2)	<p>a. Check to see that all canvas parts are secured to the metal frame assembly.</p> <p>b. Check to see that canvas areas are not torn and all straps are attached to the canvas assembly.</p>
8	Bag, Cotton Duck CW-503/PRC-25	<p>a. Check to see that the canvas is not worn or frayed and is serviceable.</p> <p>b. Check to see that the two metal fasteners are secured to the bag.</p>
9	Performance Check	Perform the operational checks listed in paragraphs 5-6 and 5-7.

i. The Item No. column in table 5-1 shall be used as a source of item numbers for the TM item number column on DA Form 2404 (Equipment Inspection and Maintenance Worksheet) in recording the results of the PMCS.

j. If the equipment fails to meet the criteria in the Procedures column of the table, report the failure in accordance with the procedures specified in DA PAM 738-750.

Section III. TROUBLESHOOTING

5-4. Troubleshooting

a. *Visual Inspection.* When equipment failure occurs, inspect the equipment carefully for obvious defects. This procedure will save time and may prevent further damage. If visual inspection does not reveal trouble, proceed to the equipment performance checklist (b below). Make the following visual checks:

(1) Tightness of the antenna in the antenna mount. The antenna should be screwed completely into the radio receptacle.

(2) Seating of the handset connector in the AUDIO connector. The O-ring should be in the connector and should not be loose.

(3) Check the receptacle on the battery (fig. 2-2 or 2-3) to see if wires are broken or the connectors damaged.

(4) Check the handset connector as follows:

(a) Using a soft tool (such as a piece of wood), press in each pin contact; each contact should sprung in and out.

(b) The plastic base that holds the 5 pin contacts is not cracked or rotated out of position.

(c) The studs (3 of them) that lock into the RT-841/PRC-77 AUDIO connector grooves are not missing.

b. *Troubleshooting Procedure.* Procedures for checking the performance of the radio set are given in (1) and (2) below. If the corrective measures do not clear the trouble, troubleshooting is required by higher maintenance category. Report the trouble on appropriate form (DA Pam 738-750), indicating the specific trouble and what corrective measures were taken.

(1) Perform the procedures in paragraph 4-5. Refer to TM 11-5820-667-20P for organizational repair parts for the AN/PRC-77.

(2) To check the transmitting power, use the AN/PRM-34 (para 5-6). If no rf power indication is obtained, and the distant radio cannot hear the transmission using the 3-foot AT-892/PRC-25 or 10-foot AT-271A/PRC, refer the RT-841/PRC-77 to higher category maintenance for repair.

5-5. Repair

Organizational repair parts for the radio are provided in TM 11-5820-667-20P. No instructions are required to remove and install the parts.

5-5.1 Connector Gasket and O-Ring Replacement (fig. 5-1)

WARNING

Make sure the J4 connector gasket and O-rings are in place, undamaged and well-fitting. If those conditions are not met, hydrogen gas (a by-product of magnesium battery BA-4386/U discharge action) can enter the RT-841/PRC-77 case. Injury to personnel and severe damage to the equipment can result if the gas explodes.

a. Inspect the O-rings on connector J4. If either or both O-rings are cut or sheared, or are loose in their

recesses, they must be replaced. Remove the defective O-ring(s). Prior to installation, coat the replacement O-ring(s) with Dow Coming No. 4 silicone grease, or equivalent. Carefully place the mating part in position and slowly increase force until the O-ring is fully engaged (seated under tension).

b. Inspect the sealing gasket on connector J4. If it is cut, sheared or out of shape, it must be replaced. If none is present, a gasket must be installed before operating the RT-841/PRC-77. The gasket must be flush with the base of the connector and with the body of the connector. It must not rest on the connector screws. prior to installation, coat replacement gasket with Dow Corning No. 4 silicone grease, or equivalent.

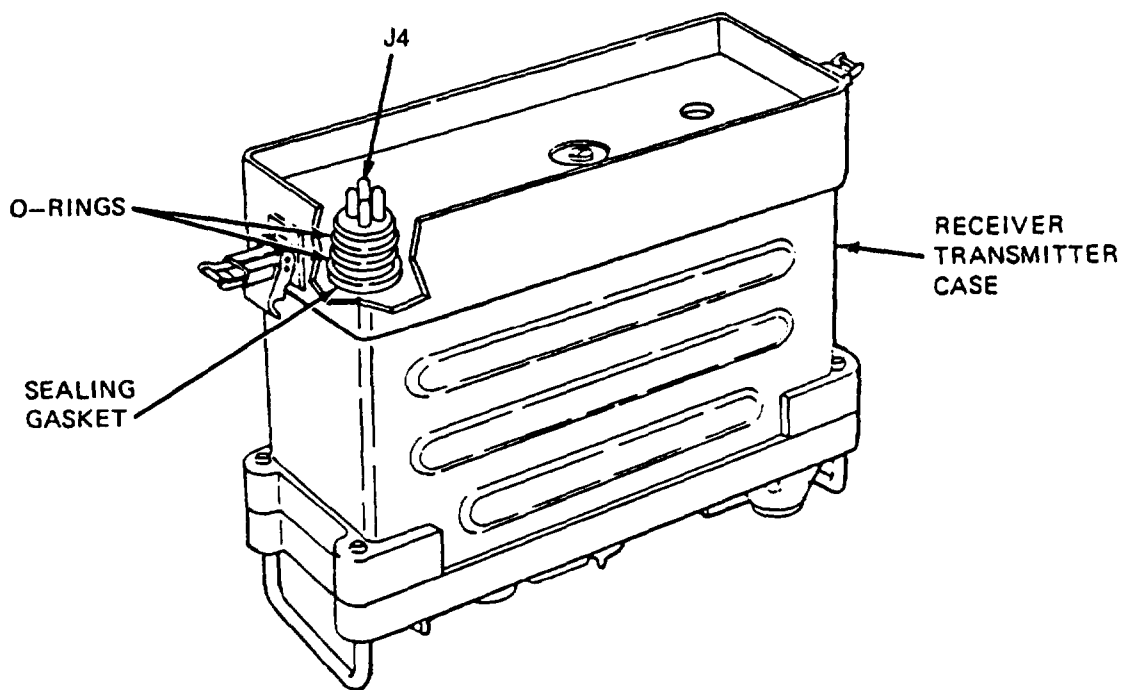

4965-001

Figure 5-1. Connector Gasket and O-Ring Replacement.

5-6. Use of Test Set, Radio AN/PRM-34

The AN/PRM-34 (TM 11-6625-3015-14) tests the RT-841/PRC-77 for receiver sensitivity and squelch response, and transmitter frequency and power output.

a. General. Since the AN/PRC-34 is connected between the coaxial antenna (ANT) connector on the radio and a dummy load for the tests (not the whip antenna connector), the transmit power test will only indicate whether sufficient or insufficient output power is available.

b. Tests. Refer to TM 11-6625-3015-14 and perform the following tests. If the RT-841/PRC-77 fails any of the tests, refer the unit to higher category maintenance for repair.

(1) *Test connections.* Use a dummy load for the transmitter tests. The dummy load is not connected to the AN/PRM-34 for receiver tests.

(2) *Differences between AN/PRC-34 serial numbers.* Test sets having serial numbers 1 through 634 are calibrated to measure accurately at and above three watts. Test sets with serial numbers 635 and higher are calibrated to measure power at and above one watt. Since the RT-841/PRC-77 may transmit below three watts on some frequencies, the following procedure must be performed, when using a test set with a serial number below 635, before taking forward power readings.

(a) Without keying the transmitter, set the AN/PRM-34 MODE switch to FWD PWR and press the PUSH TO TEST button.

(b) Record the figure (detector offset reading) on the display.

(c) When the transmitter is keyed for forward power testing, subtract the detector offset value from those levels that are below three watts for true power indication.

(3) *Squelch response test.*

(a) On the RT-841/PRC-77, turn the BAND switch to 53-75 (high band), set the REC-TRANS FREQUENCY setting to 75.00 MHz, turn the function switch to SQUELCH and turn the VOLUME switch to midrange. On the AN/PRM-34, turn the MODE switch to SEN SQ.

(b) Connect the test cable (provided with test set) between the RT-841/PRC-77 ANT connector and the AN/PRM-34 RADIO connector. Connect the handset to the RT-841/PRC-77 AUDIO connector.

(c) Push the PUSH TO TEST button. A 900 Hz tone should be heard in the handset.

(4) *Receiver sensitivity test.*

(a) On the RT-841/PRC-77, turn the BAND switch to 53.75 (high band), set the REC-TRANS FREQUENCY setting to 70.00 MHz, turn the function switch to ON and turn the VOLUME setting to midrange. On the AN/PRM-34, set the MODE switch to ON.

(b) Connect the test cable (provided with test set) between the RT-841/PRC-77 ANT connector and the AN/PRM-34 RADIO connector. Connect the handset to the RT-841/PRC-77 AUDIO connector.

(c) Push the PUSH TO TEST button. Background noise should abate and a 900 Hz tone should be heard in the handset.

(d) Repeat step (c) for all frequencies at 5 MHz intervals from 35 to 70.

(5) *Transmitter frequency accuracy test.*

(a) On the RT-841/PRC-77, turn the BAND switch to 53-75 (high band), set the REC-TRANS FREQUENCY to 75.00 MHz and turn the function switch to ON. On the AN/PRM-34, set the MODE switch to FREQ.

(b) Connect the test cable (provided with test set) between the RT-841/PRC-77 ANT connector and the AN/PRM-77 RADIO connector. Connect the handset to the RT-841/PRC-77 AUDIO connector.

(c) Connect an antenna or dummy load to the AN/PRM-77 ANT connector.

(d) Key the radio and push the PUSH TO TEST button. The test set will indicate transmitter frequency. The frequency indication should be within ± 5 kHz (0.005 MHz) of the RT-841/PRC-77 dial setting.

NOTE

When using a test set with a serial number lower than 635, indications will be inaccurate for frequencies that transmit below three watts. However, if all frequencies respond to the receiver sensitivity test ((4) above), it can be presumed that the transmitter frequencies are accurate.

(e) Repeat step (d) for the following REC-TRANS FREQUENCY dial settings: 75.05, 75.10, 75.15, 75.20, 75.25, 75.30, 75.35, 75.40, 75.45, 75.50, 75.55, 75.60, 75.65, 75.70, 75.75, 75.80, 75.85, 75.90, 67.00, 62.00, 58.00, 54.00, 50.00, 44.00, 39.00, 35.00 and 31.00.

(6) *Transmitter forward power test.*

(a) On the RT-841/PRC-77, turn the BAND switch to 30.52 (low band) and set the function switch to ON. On the AN/PRM-34, set the MODE switch to FWD PWR.

(b) Connect the test cable (provided with test set) between the RT-841/PRC-77 ANT connector and the AN/PRM-34 RADIO connector. Connect the handset to the RT-841/PRC-77 AUDIO connector.

(c) Connect an antenna or dummy load to the AN/PRM-34 ANT connector.

NOTE

When using a test set with a serial number lower than 635, refer to paragraph (2) above before performing step (d).

(d) Key the radio and push the PUSH TO TEST button. The test set display will indicate forward power. For all frequencies, the test set indication should be between 1.0 and 4.0 watts. If the RT-841/PRC-77 is connected to an antenna, reflected power applies. Reflected power should not be greater than one third of forward power.

(7) Reverse power test.

(a) On the RT-841/PRC-77, set the function to ON. On the AN/PRM-34, turn the MODE switch to RVS PWR.

(b) Connect the test cable between the RT-841/PRC-77 ANT connector and the AN/PRM-34 RADIO connector. Connect the handset to the RT-841/PRC-77 AUDIO connector.

(c) Connect an antenna or dummy load to the AN/PRM-34 ANT connector.

(d) Key the radio and push the PUSH TO TEST button. The test set display will indicate reverse power. If the RT-841/PRC-77 is connected to an antenna, reflected power applies. Reflected power should not be greater than reverse power.

NOTE

When using a test set with a serial number lower than 635, measurements for frequencies transmitting at less than three watts will be inaccurate.

5-7. Use of Test Set, Power TS-2609/U

The TS-2609/U is a small thru-line directional wattmeter which measures and monitors transmitter radiofrequency

(RF) power and load match (reflected power) in 50-ohm impedance coaxial systems. It measures forward and reflected power from 0 to 100 watts and 0 to 10 watts in 30.00 to 76.00 MHz range with an accuracy of 5 percent of full scale at room temperature. It provides no loss to transmitted and received RF signals; thus it may be connected to the radio during normal transmission and reception.

a. Since the TS-2609/U is connected between the coaxial ANT receptacle and a 50-ohm antenna system or dummy load (not the whip antenna receptacle of the RT-841/PRC-77), the test would only indicate whether the RT-841/PRC-77 has sufficient or insufficient output RF power. If insufficient output power (*b(3)* below) is obtained, communication failure could be attributed to one of the following: whip antenna (3 or 10 ft); weak battery; handset modulation or demodulation circuits.

b. Since the TS-2609/U cannot be connected to the whip antenna connector of the RT-841/PRC-77, use a vehicular whip antenna system of another radio set, such as the AS-1729/VRC (or AT-912/VRC) of the AN/VRC-12 series radios (TM 11-5820-401-10-1, 10-2,20-1, 20-2) or of Radio Sets AN/VRC-53, AN/VRC-64, AN/GRC-125, or AN/GRC-160 (TM 11-5820-498-20). To perform the test proceed as follows. Refer to TM 11-6625-1686-15 for instruction on connections and operation of the TS-2609/U.

(1) Leave the battery in the RT-841/PRC-77 and connect the TS-2609/U between the RT-841/PRC-77 and the vehicular whip antenna system.

(2) Key the RT-841/PRC-77 at the frequency at which communication fails and at other frequencies in both bands.

(3) The forward power indication should range between 1.0 and 4.0 watts, depending on frequency. Under normal operating conditions, the minimum power output shall be as follows (these values will be slightly lower under extreme temperature conditions):

<u>Frequency Range (MHz)</u>	<u>Power (Watts)</u>
30.00-33.95	1.75
34.00-49.95	2.00
50.00-52.95	1.75
53.00-70.95	1.5
71.00-75.95	1.3

CAUTION

Never change frequencies or the BAND switch while the transmitter is keyed (by pressing the handset push-to-talk switch). To do so damages modules in the radio or may cause the wrong frequency to be set up for transmission or reception.

5-8. Inspecting RT-841/PRC-77 for Condition of Hydrogen Gas Protection Devices

CAUTION

Explosive hydrogen gas is a by-product of the discharge action of Magnesium Battery BA-4386/U. This gas must be vented to prevent its leaking into the RT-841/PRC-77 chassis. Hydrogen gas can cause explosions which can injure personnel and severely damage equipment.

Perform the following operations periodically on the RT-841/PRC-77 to purge hydrogen gas (*b* below) that may

accumulate in the chassis from the magnesium battery (para 1-11a(3)), and to inspect the items that help prevent hydrogen gas from leaking into the chassis (*c*, *d*, and *e* below). When any item in *c*, *d*, or *e* below is defective, it must be corrected before the radio is used for communication.

a. Stand the RT-841/PRC-77 on its front panel (fig. 2-3). Remove the CY-2562/PRC-25 and the battery (para 2-4*a, b*, and *c*). Loosen the captive screws and pull the case from the RT-841/PRC-77 chassis.

b. Blow out all parts on both sides of the RT-841/PRC-77 chassis. Use lung power.

c. Inspect RT-841/PRC-77 battery connector for the following:

(1) A rubber gasket (NSN 5330-01-049-0038) (shaped similarly to the metal ring around the battery connector hole in the RT-841/PRC-77 case) must be installed on the RT-841/PRC-77 battery connector. It must be undamaged, (and inside the four connector mounting screws), and flush with the body of the connector. Coat the gasket with Dow Corning No. 4 silicone grease (Item 2, appendix E) or equivalent.

(2) The two O-rings (NSN 5330-00-551-8250) (preformed packing) on the battery connector must be installed and undamaged. That is, they must not be sheared, and each O-ring must be seated, under tension, in its recess. Lubricate O-rings with Dow Coming No. 4 silicone grease or equivalent before installation. Carefully place mating part in position and slowly increase force until the O-ring is fully engaged.

(3) The three battery connector pins must not be bent or otherwise damaged.

d. In the RT-841/PRC-77 case (fig. 2-3), the pressure test screw must be screwed tightly closed and covered with an epoxy (NSN 8040 -00-753-4800 or equivalent) to insure that it is sealed and cannot be loosened. (The hole was used in manufacture for pressure test instruments.) Seal the guide pin bushing staked to the header with epoxy.

e. The pressure relief valve (fig. 2-3) must be installed in the CY-2562/PRC-25 (para 1-11a((3))). Inspect the pressure relief valve to see if it is free of dirt and operating correctly.

CHAPTER 6

MATERIEL USED IN CONJUNCTION WITH RADIO SET

AN/PRC-77

6-1. Radio Relay Procedures and Retransmission Cable Kit MK-456/GRC

With Cable Assembly, Special Purpose, Electrical CX-4656/GRC from Retransmission Cable Kit MK-456/GRC (fig. 6-1), two compatible FM radios may be used as a radio relay for other radio sets that are too far distant to communicate directly with each other. The radio relay can be accomplished by interconnecting the radios listed in paragraph 3-10c(1), (2), and (3) with the CX-4656/GRC as shown in figure 6-3.

a. MK-456/GRC. The MK-456/GRC (fig. 6-1 and 6-2) consists of Bag, Cotton Duck CW-502/PRC and 50-foot cable assembly CX-4656/GRC. The network box has an audio connector to which a handset or audio accessory is attached to monitor (listen to) the signals being retransmitted in both directions.

b. Selection of Frequencies.

(1) *Interference problems.* When frequencies that are to be used for retransmission are planned, the two frequencies must be at least 3 MHz apart and must be selected so that the transmitter of neither radio will interfere with the receiver of the other, as shown in the retransmission interference chart (fig. 6-19).

(2) *Use of interference chart.* Each square on the retransmission interference chart (fig. 6-19) represents the intersection of two frequencies. The transmitter frequency is in MHz and is plotted from left to right; the receiver frequency is in MHz and is plotted from bottom to top. The black areas represent frequencies at which interference will occur; the white areas represent frequencies at which interference will not occur. There are five channels per square of the chart. Examples of use of the chart are given in (a) and (b) below.

(a) A transmitter frequency of 54 MHz will not interfere with a receiver frequency of 32 MHz.

(b) A transmitter frequency of 54 MHz will interfere with a receiver frequency of 31 MHz.

NOTE

Trial and error checks may disclose that frequencies other than those given in the chart are interfering frequencies. Record these frequencies for future use.

c. Retransmission Requirements. Figure 6-3 shows the connections between an AN/PRC-77 (radio set No. 2) and another radio set at the relay site. The chart in figure 6-3 shows the settings of the squelch-functioning switches required at the various sets in the radio net. In general, the relay site radios must operate with squelch signals being received from the distant radios (radio sets No. 1 and No. 4). Refer to paragraph 3-10c(1) through (3) and figure 3-3 for FM radios that can communicate with each other in a radio net.

d. System Lineup. Refer to figure 6-3 for the discussion in (1) through (9) below.

(1) Set up each radio at the relay site and at the distant radio sets to operate without squelch.

(2) Set the operating frequency of radio sets No. 1 and No. 2 on the same frequency, F1. Set the operating frequency of radio sets No. 3 and No. 4 on another frequency, F2 (*b* above).

(3) Establish communication between radio sets No. 1 and No. 2 and between radio sets No. 3 and No. 4.

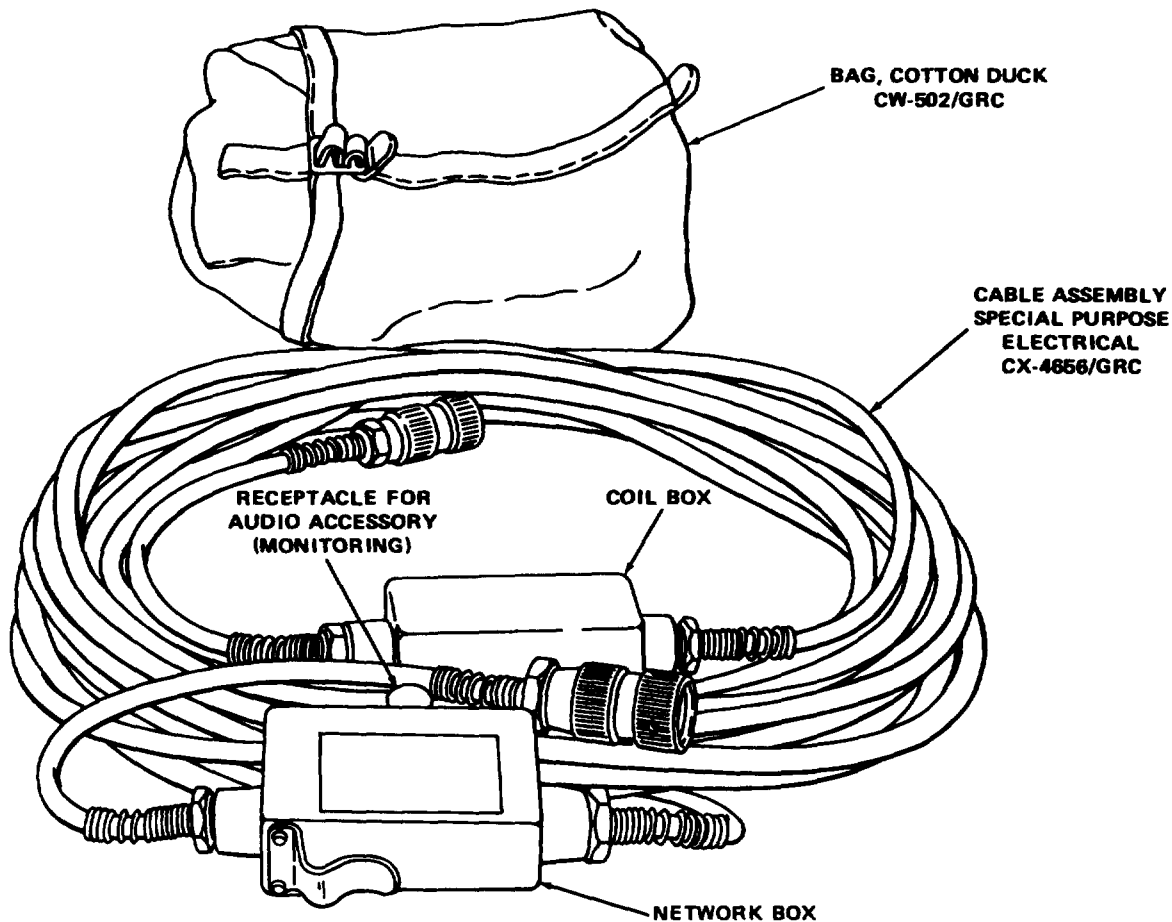

EL3YR028

Figure 6-1. Retransmission Cable Kit MK-456/GRC.

(4) When communication is satisfactorily established between the associated radio sets, adjust each radio to operate on squelch (see chart, fig. 6-3). Check for satisfactory communication on squelch operation between the associated pairs of radio sets (No. 1 and No. 2; No. 3 and No. 4).

(5) When operation on squelch between the radio sets is satisfactory, advise the radio operators at radio sets No. 1 and No. 4 to stand by while the following arrangements are being made:

(a) When the RT-841/PRC-77 at the relay site is connected in retransmission to another RT-841/PRC-77 or an RT-505/PRC-25, connect

the connectors on the ends of the CX-4656/GRC to an AUDIO connector on each receiver-transmitter. On each receiver-transmitter, set the function switch to RETRANS.

(b) When the RT-841/PRC-77 at the relay site is connected for retransmission to the RT-246/VRC or RT-524/VRC of the AN/VRC-12 radio series, connect one end of the CX-4656/GRC to an AUDIO connector of the RT-841/PRC-77 and connect the other end of the CX-4656/GRC to the RETRANSMIT R/W connector of the RT-246/VRC or RT-524/VRC. Set the function switch of the RT-841/PRC-77 to RETRANS. Set the SQUELCH switch of the RT-246/VRC or RT-524/VRC to NEW ON

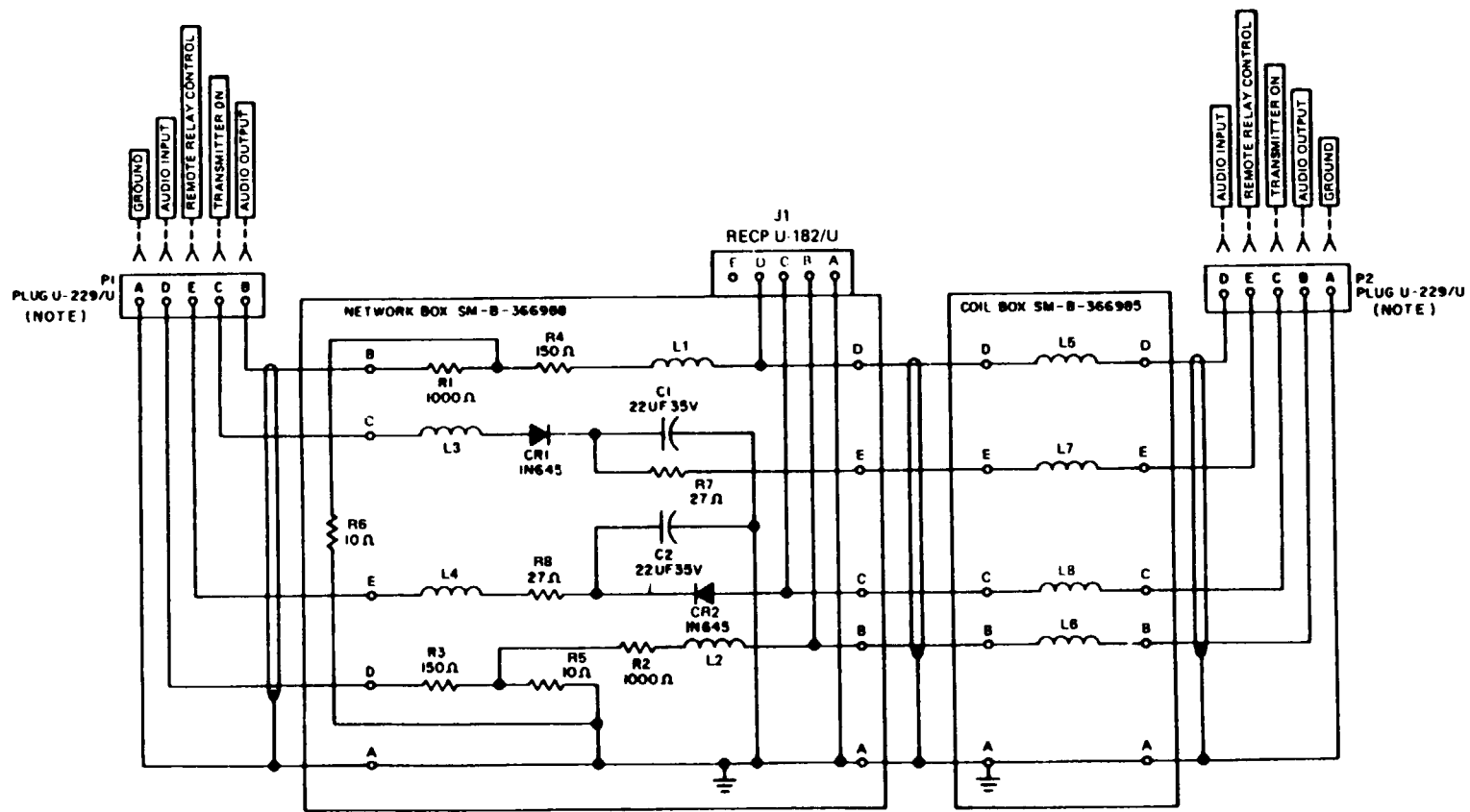

NOTE:
 PLUG U-182/U WAS USED ORIGINALLY;
 IF REPLACED, USE U-229/U.

EL3YR029

Figure 6-2. Cable Assembly, Special Purpose, Electrical CX-4656/GRC,
 Schematic Diagram.

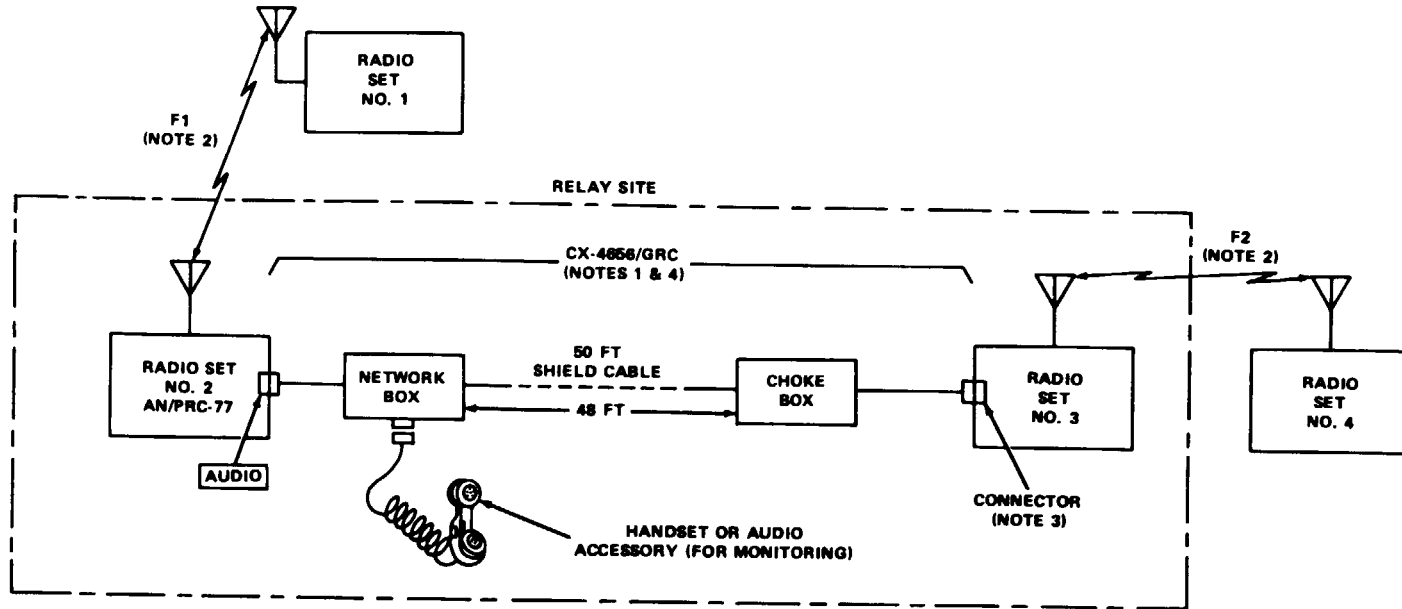

NOTES:

1. PART OF MK-456/GRC.
2. FREQUENCIES FOR F1 AND F2 ARE SELECTED FOR NON INTERFERENCE.
3. WHEN RT-505/PRC-25 OR RT-841/PRC-77 IS USED, CONNECT CABLE TO **AUDIO** CONNECTOR; WHEN RT-246/VRC OR RT-524/VRC IS USED, CONNECT CABLE TO **RETRANSMIT R/W** CONNECTOR.
4. RADIO SETS NO. 2 AND NO. 3 AT RELAY SITE SEPARATED BY FULL LENGTH (50 FT) OF CX-4656/GRC.
5. INDICATES EQUIPMENT MARKING.
6. SWITCH POSITIONS REQUIRED FOR VARIOUS RADIOS IN THE RADIO RELAY NET, AS SHOWN IN TABLE.

TERMINAL RADIO		RADIO RELAY SITE				TERMINAL RADIO	
RADIO SET NO. 1		RADIO SET NO. 2		RADIO SET NO. 3		RADIO SET NO. 4	
RADIO	SWITCH	RADIO	SWITCH	RADIO	SWITCH	RADIO	SWITCH
RT-505/ PRC-25 OR RT-841/ PRC-77	FUNCTION: SQUELCH	RT-841/ PRC-77	FUNCTION: RETRANS	RT-505/PRC-25 OR RT-841/PRC-77	FUNCTION: RETRANS	RT-505/ PRC-25 OR RT-841/ PRC-77	FUNCTION: SQUELCH
RT-246/VRC OR RT-524/VRC	SQUELCH: NEW ON, NEW OFF, OR OLD OFF			RT-246/VRC OR RT-524/VRC	SQUELCH: NEW ON,	RT-246/VRC OR RT-524/VRC	SQUELCH: NEW ON, NEW OFF OR OLD OFF
AN/ARC-54 OR AN/ARC-131	SQUELCH: TONE			RT-246/VRC OR RT-524/VRC	SQUELCH: OLD ON	AN/ARC-54 OR AN/ARC-131	SQUELCH: TONE
						COMPATIBLE FM RADIO SET OTHER THAN THOSE LISTED ABOVE	NOT APPLICABLE

Figure 6-3. Radio Relay Connections and Conditions.

EL3YR030

when the radio set with which it communicates is one of those given in paragraph 3-10c(1), (2), and (3); set the SQUELCH switch to OLD ON for any other radio set.

(6) Communicate with radio set No. 1 from radio set No. 2, and advise the radio set No. 1 operator that the relay site is prepared for communication with radio set No. 4.

(7) Communicate with radio set No. 4 from radio set No. 3, and advise the radio set No. 4 operator that the relay site is prepared for communication with radio set No. 1.

(8) Communication proceeds automatically between radio sets No. 1 and No. 4 without any operation required at the relay site.

(9) For the operator at the relay site to receive instructions and to monitor the communication between radio sets No. 1 and No. 4, connect a handset to the audio connector on the network box of the CX-4656/GRC. To communicate with radio set No. 1 or No. 4, the operator at the relay site must use the relay site radio set associated with the distant radio set.

6-2. Batteries

a. Battery, non-rechargeable BA-5598/U is used in place of other batteries to supply power during arctic operation. The average life of the BA-5598/U under arctic conditions is approximately 42 hours at 0°F(-18°C) and 30 hours at -40°F(-40°C). Two required.

b. Battery, dry BA-4386/U is a long-life 15-volt magnesium battery used under normal conditions.

c. Battery, rechargeable BB-586/U is a nickel-cadmium battery capable of a minimum of 200 charge-discharge cycles before disposal. The battery is charged at 800 mA (4/5 rate) for six hours using Charger PP-7286/U. Two batteries are required.

6-3. Antenna Equipment RC-292 and Antenna Group OE-254/GRC

WARNING

Operators must become familiar with the requirements of TB43-0129 and the warnings on the warning pages. Failure to do so can result in death should an antenna contact any power line.

The RC-292 and OE-254/GRC are elevated, ground-plane antennas that may be used to extend the operating distance of fm radios in 30 to 76 MHz range when the radios are used in a fixed or permanent location. These antennas are connected to the ANT connector (fig. 3-1). Installation instructions for the OE-254/GRC are contained in TM 11-5985-357-13 and in TM 11-5820-348-15 for the RC-292. Operation of the radio set is unchanged when these antennas are used. The vertical and ground-plane elements of the OE-254/GRC are unchanged for all operating frequencies of the radio. The number of RC-292 elements required for vertical and ground-plane sections for a given frequency band areas listed in table 6-1.

6-4. Antenna. Homing Loop AT-784/PRC (fig. 6-5)

Antenna, Homing Loop AT-784/PRC is used for detection and location of radio signals in the 30 to 76 MHz range. It consists of the components shown in figure 6-5. Cable Assembly, Radio Frequency CG-3344/PRC is for connecting the radio set and Antenna AT-1082/PRC. Cap, Electrical CW-922/GRC, which is attached to the CG-3344/PRC, is used as a grounding cap and must be connected to the 3- and 10-foot whip antenna connectors. The CW-922/GRC is used to prevent possible radio-frequency radiation from this antenna connector from interfering with the sensing operation of the AT-1082/PRC. Cable Assembly, Radio Frequency CG-2840A/U is connected to the CG-3344/PRC to extend the distance between the radio set and the AT-1082/PRC. Refer to TM 11-5985-284-15 for operating instructions with radio sets such as the AN/PRC-77.

Figure 6-4. Deleted.

Table 6-1. RC-292 Element Requirements

Operating Frequency (MHz)	No. of Vertical Sections Required	Type of Antenna Section Used				No. of Ground-Plane Sections Required for All Legs	Type of Ground-Plane Section Used in Each Leg			
		AB-21/GR	AB-22/GR	AB-23/GR	AB-24/GR		AB-21/GR	AB-22/GR	AB-23/GR	AB-24/GR
30 to 35.5	4	1	1	1	1	15	2	1	1	1
36.5 to 50.5	3	0	1	1	1	12	1	1	1	1
50.5 to 75.95	2	0	1	0	1	9	0	1	1	1

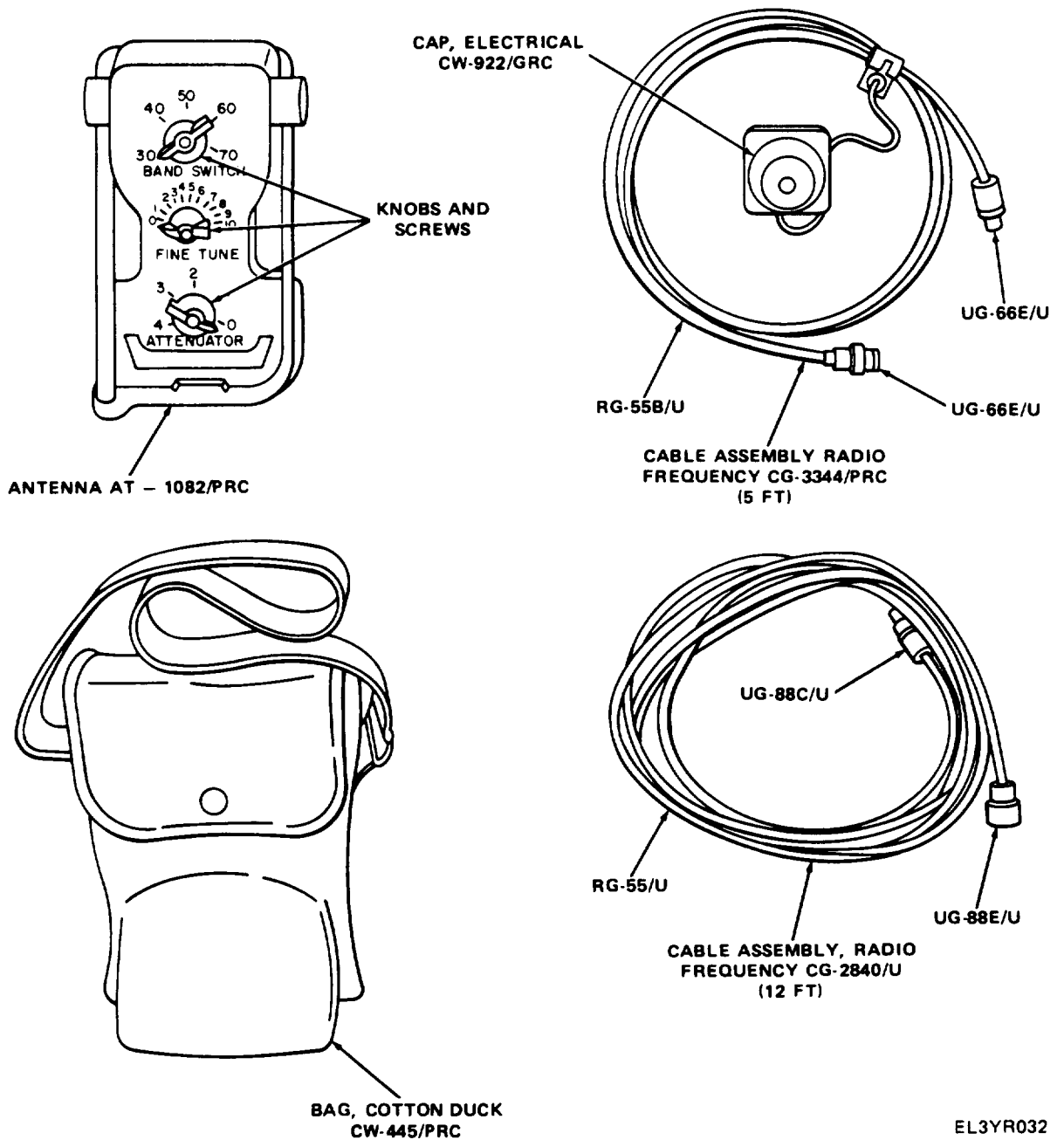

EL3YR032

Figure 6-5. Antenna Homing Loop AT-784/PRC.

6-5. Antenna AT-984A/G Installation and Maintenance (fig. 6-6)

WARNING

Operators must become familiar with the requirements of TB SIG 291 and the

warnings on the warning pages. Failure to do so can result in death should an antenna contact any power line.

Antenna AT-984A/G (NSN 5820-00-926-0201) is a long-wire, multiple wavelength antenna that

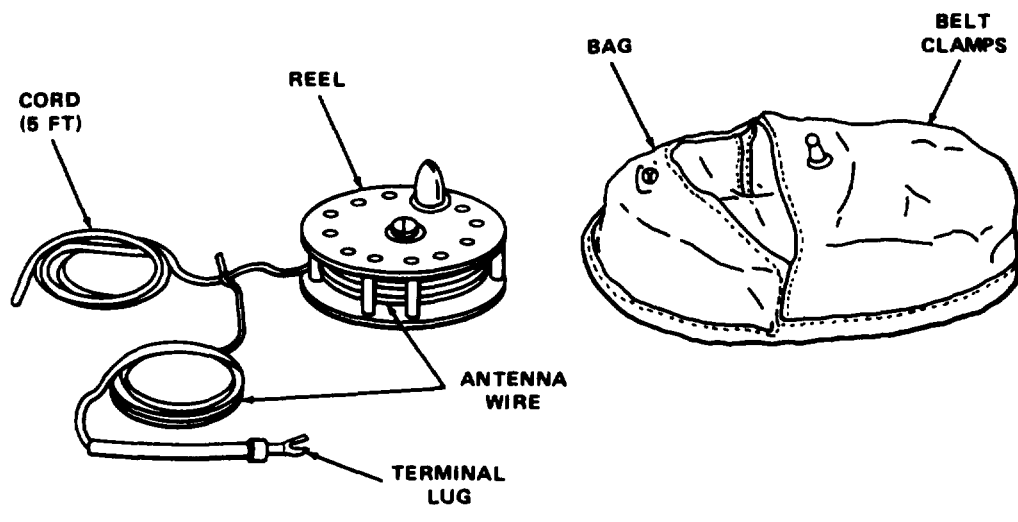

EL3YR033

Figure 6-6. Antenna AT-984A/G, Components.

is used to extend the normal transmission and reception range of radio sets that are provided with the RT-505/PRC-25 and RT-841/PRC-77.

a. Description. The AT-984A/G consists of a canvas bag and 150 feet of antenna wire wound on a reel. The antenna wire is connected to the reel with a nylon cord (fig. 6-9). A cord at the other end of the wire is used to suspend the antenna wire during operation of the radio set. The end of the antenna wire is soldered to a terminal lug that is crimped around the wire and the insulating tubing to strengthen the connection. The canvas bag has two locking devices on the rear for attachment to the belt of the user while he is unwinding the antenna wire with the reel inside the bag.

b. Siting and Installation.

(1) *Siting* (fig. 6-7). The operating range of the AN/PRC-77 is primarily the line of sight. That is, if the location of the other radio station can be seen, transmission and reception will probably be satisfactory. An intervening hill or tall building may hamper or prevent contact with the other station.

(a) Avoid siting the radio set in valleys, densely wooded areas, and low places. Location on a hilltop will increase the operating range if the other station's location can be seen.

(b) Avoid siting the radio set near interference sources such as power or telephone lines, radar sets, and field hospitals.

(c) Make sure that there are no obstacles preventing the antenna wire from being extended its full length of 150 feet in a straight line toward the other station. Transmission and reception with a long-wire antenna is off the end of the antenna in the direction away from the radio set.

(2) *Installation.* The speed of the reel action can be varied by changing the position of the button on the side of the reel. With the button in one position, the reel turns slowly because the ratchet is engaged. With the button on the other position, the reel turns freely because the ratchet is not engaged.

(a) Connect the terminal lug at the end of the antenna wire to the radio set as given in 1 through 3 below. Figure 6-8 shows the connection to the RT-841/PRC-77.

1. Remove the long whip antenna AT-271A/PRC from Support, Antenna AB-591/PRC-25.

2. Unscrew the AB-591/PRC-25 slightly, and insert the lug of the antenna wire under it.

3. Tighten the AB-591/PRC-25.

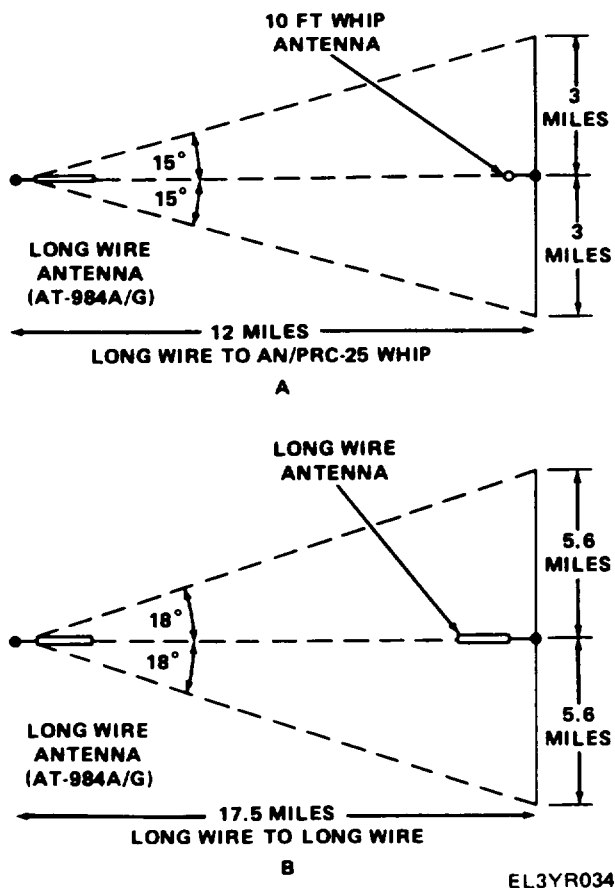

Figure 6-7. AT-984A/G, Radiation Patterns and Siting Diagram.

4. When the antenna is aimed toward the other radio station that is also equipped with a long-wire antenna, the area of communication covers 18 degrees of azimuth on either side of the line along which the antenna is aimed (B, fig. 6-7). If the other station is equipped only with a whip antenna, the area of communication covers only 15 degrees (A, fig. 6-7).

(b) Tie the cord that is attached to the antenna wire to a nearby support that is capable of supporting the antenna wire when it is stretched to the other support 150 feet away.

(c) Unreel the antenna wire by moving in the direction of the other radio station.

NOTE

If canvas bag is available, unreel antenna wire without handling reel by attaching canvas bag to trouser belt and placing reel in canvas bag.

(d) Stretch the antenna wire approximately 4 feet above the ground by securing the reel to a building, tree, post, or similar support. Use the cord that ties the antenna wire to the reel (fig. 6-9).

WARNING

If the tactical situation permits, use warning signs or similar safety measures to prevent personnel and vehicles from running into the stretched antenna wire.

c. *Maintenance.* There are no maintenance parts for the AT-984A/G.

(1) If the terminal lug is broken, damaged, or lost, cut off the rubber tubing immediately behind the terminal lug (fig. 6-9), and cut back the tubing to expose $\frac{1}{4}$ inch of antenna wire. Obtain a new terminal lug; crimp the terminal lug around the tubing the same way as the old terminal lug was crimped. Solder the $\frac{1}{4}$ inch of projecting antenna wire to the terminal lug.

(2) If it is necessary to replace either of the two lengths of cord, obtain a 5-foot length of nonconductive, 100-pound test, olive-drab cord. To prevent the nylon cord from unraveling, put the end above a flame momentarily.

WARNING

The fumes of trichlorotrifluoroethane are poisonous. Provide adequate ventilation whenever you use trichlorotrifluoroethane. Do not use solvent near heat or open flame. Trichlorotrifluoroethane will not burn, but heat changes the gas into poisonous, irritating fumes. Do not breathe the fumes or vapors. Trichlorotrifluoroethane dissolves natural skin oils. Do not get the solvent on your skin. Use gloves, sleeves, and an apron which the solvent cannot penetrate. If the solvent is taken internally, consult a physician immediately.

d. *Cleaning.* Unreel the antenna wire and clean it with a clean cloth. Trichlorotrifluoroethane may be used to facilitate dirt and grease removal.

6-6. Loudspeaker, Electromagnetic LS-549/PRC

This item is no longer available.

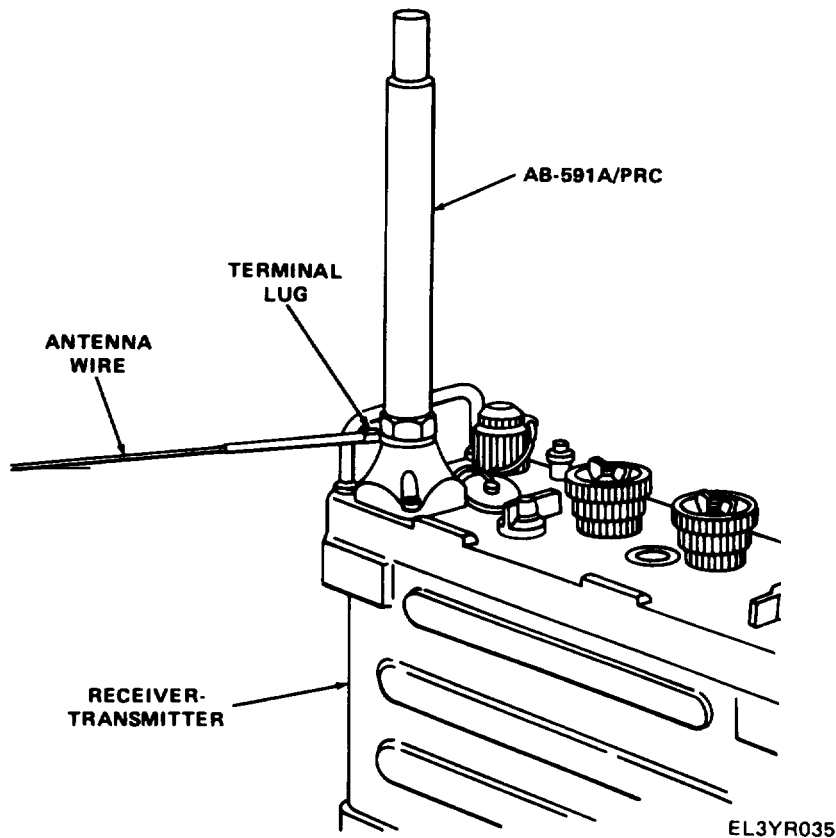

Figure 6-8. Connection of Antenna Wire of AT-984A/G to RT-841/PRC-77.

6-7. Radio Sat Control Group AN/GRA-39(*)

NOTE

Radio Set Control Group AN/GRA-39(*) represents all models of the equipment; Control, Radio Set C-2328(*)/GRA-39 represents all models of the equipment; Control, Radio Set C-2329(*)/GRA-39 represents all models of the equipment.

The AN/GRA-39(*) may be used to provide remote radio control of radio transmission and reception of the AN/PRC-77 up to approximately 2 miles (3.3 kilometers, approximately) (a below). This equipment may also be used to provide radio/wire integration (RWI) between Switchboard, Telephone SB-22/PT (switchboard) (TM 11-5805-262-

12) and the AN/PRC-77 (b below). Installation and operating instructions for the AN/GRA-39(*) are provided in TM 11-5820-477-12.

a. *Remote Radio Control.* Operation of the AN/PRC-77, as described in paragraphs 3-2 through 3-8, is unchanged except as follows:

(1) When the AN/GRA-39 or AN/GRA-39A is used and its local control, the C-2329/GRA-39 or C2329A/GRA-39, has not been modified by the application of rescinded MWO 11-5820-477-30/1 to permit use of the function switch on the RT-841/PRC-77 in the SQUELCH position, the radio communication must be conducted with the function switch set to ON only. In turn, the distant radio set in the net must also operate without squelch operation (para 3-10c(1) through (3)).

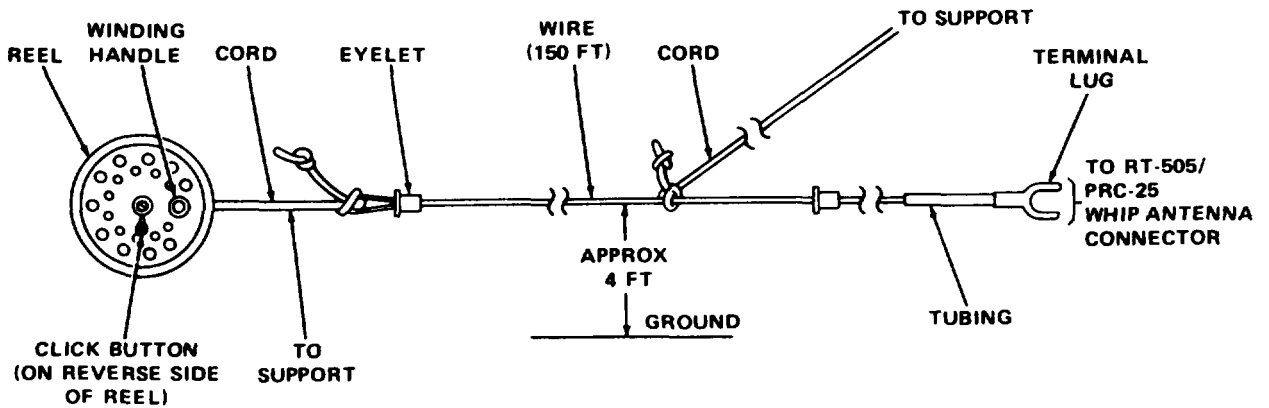

EL3YR036

Figure 6-9. Antenna AT-984A/G, Installation and Parts

(2) When the AN/GRA-39B (in which the C-2329B/GRA-39 local control box is used) or when the local control box of the AN/GRA-39 or AN/GRA-39A ((1) above) have been modified, the function switch of the RT-841/PRC-77 may be set to SQUELCH.

(3) If the radio reception is cutting in and out (caused by receiver-to-transmitter feedback loop that causes the relay in RT-841/PRC-77 to alternate between receive and transmit positions), set the VOLUME control on the RT-841/PRC-77 down to a position at which interruption of the signal ceases.

b. Radio/Wire Integration (RWI). To provide RWI between the AN/PRC-77 and an SB-22/PT, using the AN/GRA-39(*), proceed as follows:

(1) *Connections.*

(a) Prepare a Connector, Plug U-182/U (NSN 5935-00-823-0663; part of H-138(*)/U) or U-229/U (NSN 5935-00-173-8537; part of H-189/GR) with two jumper wires soldered to pins A and C (keying circuit).

(b) Position the C-2328(*)/GRA-39 remote control at the SB-22/PT, and connect the equipment as shown in A, figure 6-10.

(2) *Operation.* Since the remote control is set up at the switchboard, the switchboard operator will respond to calls from the distant radio station with the push-to-talk radio position of his headset-chestset and will use correct radio communication procedures and call signs. In effect, the switchboard operator becomes the radio operator.

(a) Set the RT-841/PRC-77 function switch and VOLUME control as given in *a(1)*, (2), and (3) above.

(b) Set the switches on the AN/GRA-39(*) control boxes as shown in A, figure 6-10.

(c) When the radio call sign is heard on the loudspeaker of the remote control, insert the operator's cord into the radio link jack and determine the desired subscriber. Advise the distant radio station to stand by while making the arrangements in 1 and 2 below (B, fig. 6-10).

1. Connect the operator's cord to the subscriber's jack, ring, and notify the subscriber of the radio call. Advise the subscriber of the call signs, and tell him to ring back when the call is completed.

2. Connect the subscriber's cord to the radio link jack.

NOTE

Operation of the switchboard headset-chestset switch to the push-to-talk *radio* position while the operator's cord is connected to the subscriber's jack will key the radio.

(d) Remove the operator's cord from the subscriber's jack.

(e) The incoming radio communication can be heard on the remote control loudspeaker; the subscriber's voice cannot be heard.

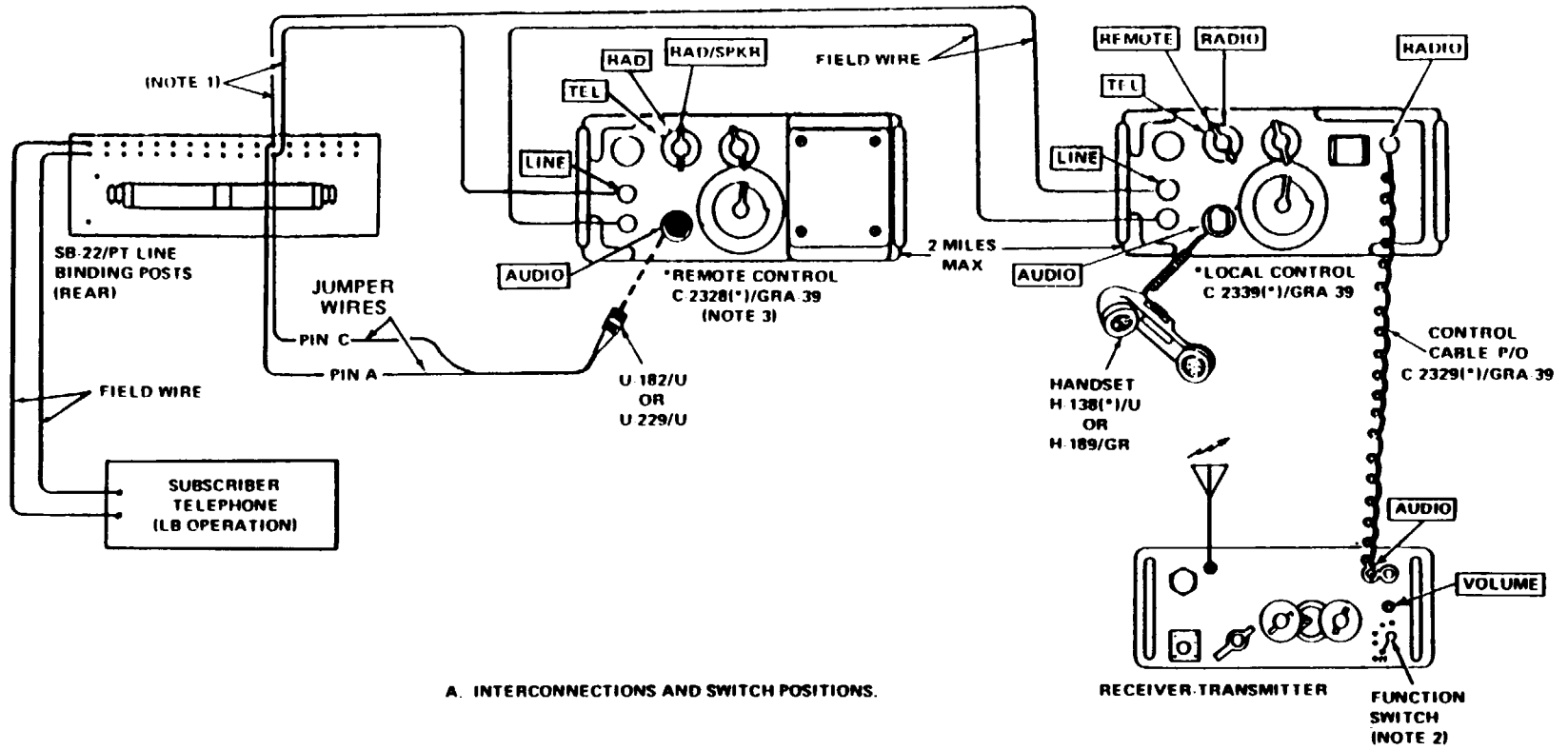

A. INTERCONNECTIONS AND SWITCH POSITIONS.

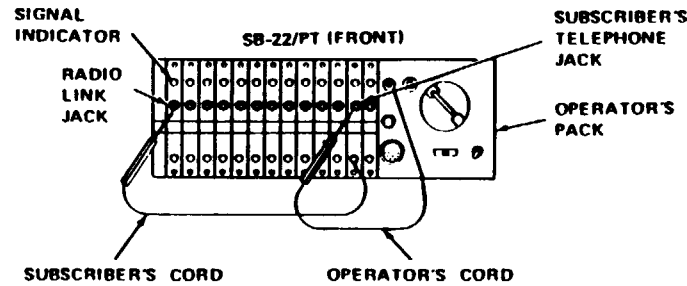

B. SWITCHBOARD CONNECTIONS FOR SUBSCRIBER RADIO LINK.

NOTES:

- * PART OF AN/GRA 39(*).
- 1. IF RECEIVER-TRANSMITTER IS KEYED, TRANSPOSE CONNECTION OF THESE WIRES AT SB 22/PT.
- 2. SQUELCH POSITION MAY BE USED WHEN C 2329B/GRA 39 IS USED, AND WHEN C 2329/GRA 39 OR C 2329A/GRA 39 HAS MWO 11 5820 477 30/1 APPLIED.
- 3. THE REMOTE CONTROL IS LOCATED NEXT TO SB 22/PT TO ENABLE SWITCHBOARD OPERATOR TO HEAR INCOMING RADIO CALLS.

EL3YR037

Figure 6-12. AN/GRA-39(*) in RWI with AN/PRC-77.

(f) When the subscriber's signal indicator shows white, insert the operator's cord into the subscriber's jack and challenge the circuit without operating the headset-chestset switch to the push-to-talk position.

(g) Remove the subscriber's cord from the radio link jack.

6-8. Radio Set Control AN/GSA-7 and Oscillator, Audio Frequency O-574/GRA

a. General.

(1) Oscillator, Audio Frequency O-574/GRA (figs. 6-11, 6-12, and 6-13) produces a

1,600 Hz ringing signal for transmission through a radio system. The O-574/GRA has two cable assemblies: Cable assembly (SC-C-75348) and Cable Assembly, Special Purpose, Electrical CX-10177/U. The cable assembly (SC-C-75348) is provided for connection between the O-574/GRA and an audio accessory such as Handset H-33/PT; the CX-10177/U is provided for connection between the O-574/GRA and the RT-841/PRC-77 and an audio accessory, such as Handset H-189/GR, combat vehicle crewman (CVC) helmet, etc.

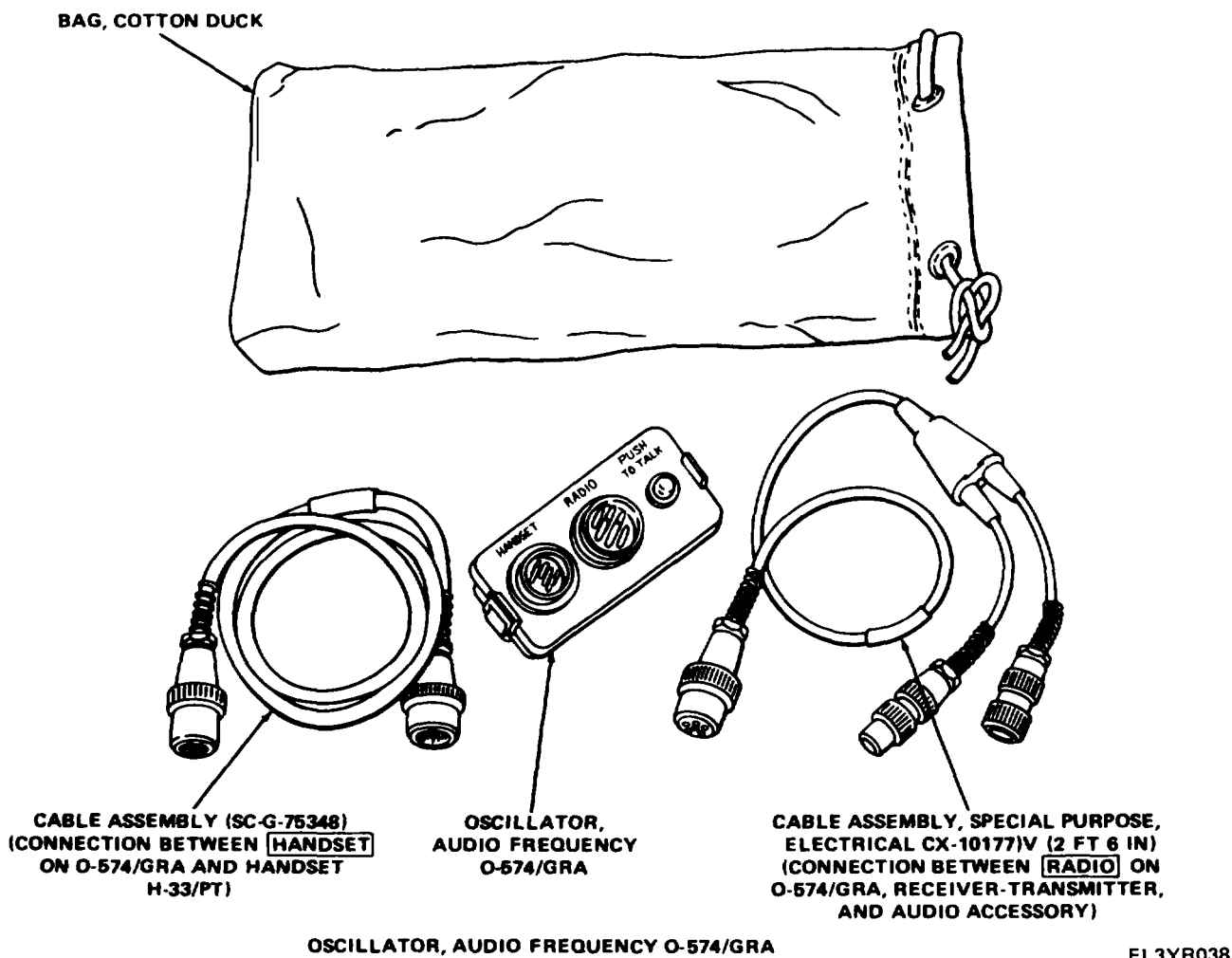
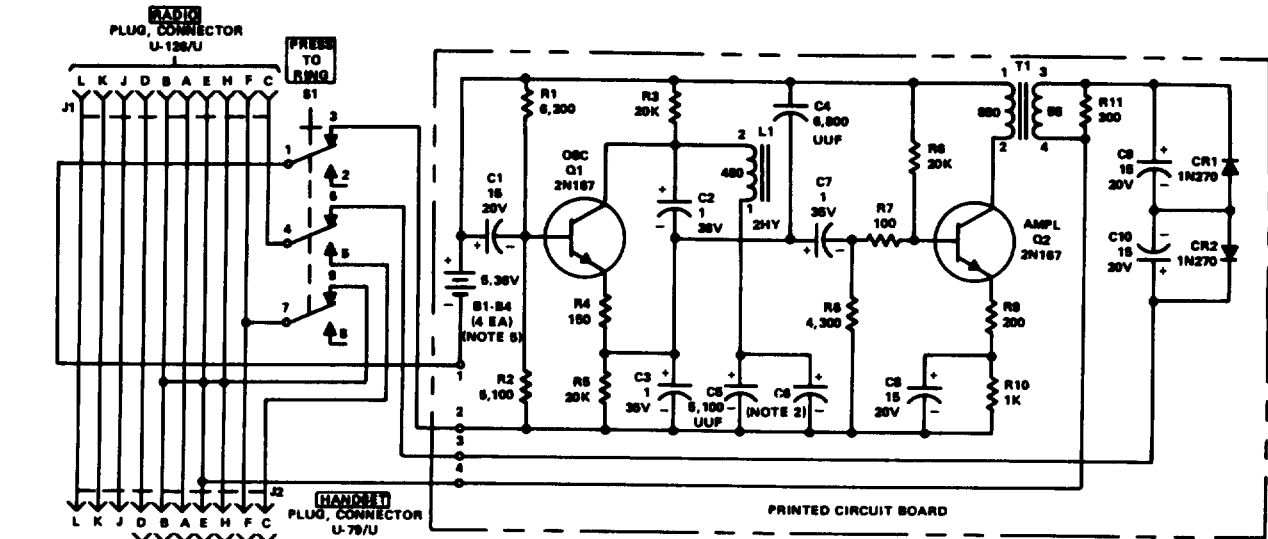
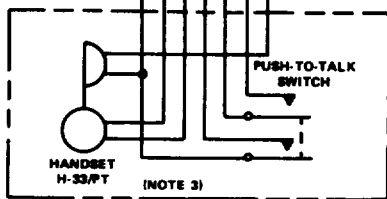

Figure 6-11. Oscillator, Audio Frequency O-574/GRA.



NOTES:

1. UNLESS OTHERWISE SPECIFIED; RESISTANCES ARE IN OHMS, CAPACITIES ARE UF.
2. FACTORY SELECTED CAPACITOR.
3. HANDSET SHOWN FOR REFERENCE ONLY, NOT PART OF O-574/GRA.
4. INDICATES EQUIPMENT MARKING.
5. BATTERIES, BA-1312/U.



A. OSCILLATOR, AUDIO O-574/GRA WITH HANDSET H-33/P.T.

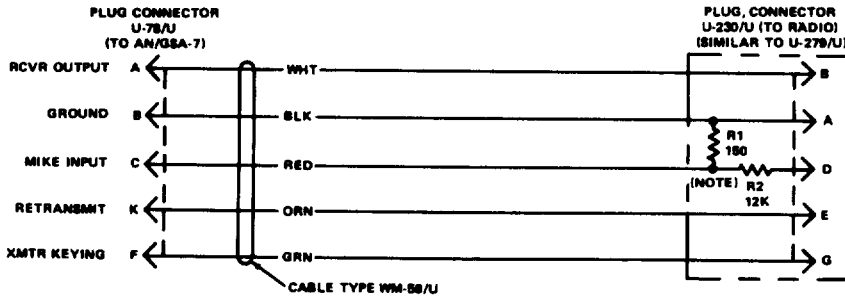

NOTE:

R1 AND R2 ARE MOLDED IN CONNECTOR PROVIDING 45 DB ATTENUATION AND ARE 1/10 W.

B. CABLE ASSEMBLY, SPECIAL PURPOSE, ELECTRICAL CX-7474/U.

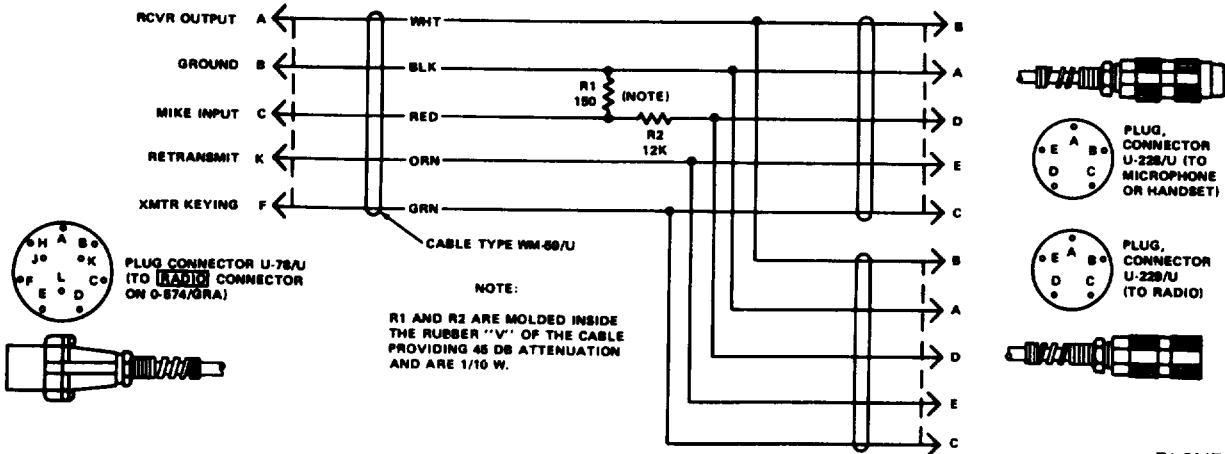

NOTE:

R1 AND R2 ARE MOLDED INSIDE THE RUBBER 'Y' OF THE CABLE PROVIDING 45 DB ATTENUATION AND ARE 1/10 W.

C. CABLE ASSEMBLY, SPECIAL PURPOSE ELECTRICAL CX-10177/U (2FT, 6 IN).

Figure 6-12. Oscillator, Audio Frequency O-574/GRA and Cable Assemblies, Special Purpose, Electrical CX-7474/U and CX-10177/U, Schematic Diagrams.

EL3YR001

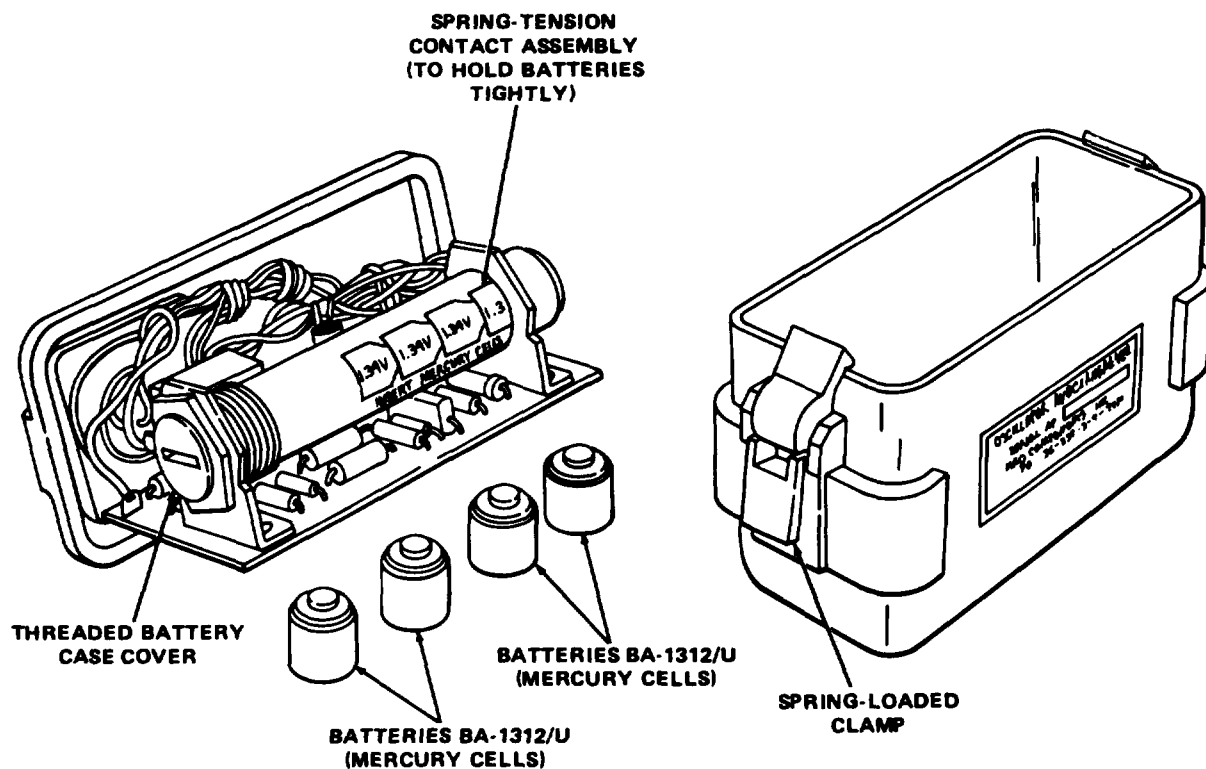

**B. OSCILLATOR, AUDIO FREQUENCY O-574/GRA WITH BATTERIES.
(LESS CABLES AND BAG)**

EL3YR039

Figure 6-13. Oscillator, Audio Frequency O-574/GRA with Batteries, Dry BA-1312/U.

NOTE

The O-574/GRA may be used with other radio sets such as the AN/VRC-12-series; the AN/PRC-77, AN/VRC-53, and Radio Sets AN/GRC-3 through AN/GRC-8, etc. The O-574/GRA is provided to radio sets in an RWI network to enable the radio operator to ring into a switchboard which is connected to another radio set through Radio Set Control AN/GSA-7 ((2) below).

(2) Radio Set Control AN/GSA-7 (TM 11-5135-15) provides RWI between Switchboard, Telephone SB-22/PT (TM 11-5805-262-12) and a radio set as far as 10 miles (16 km, approximately) distant from the radio set. With the AN/GSA-7, there are four methods of providing RWI, depending on the number of AN/GSA-7's in the system (fig. 6-15). Cable

Assembly, Special Purpose, Electrical CX-7474/U (fig. 6-14) is required for connection between the receiver-transmitter of the radio set and the AN/GSA-7.

(a) When there is an AN/GSA-7 at the other radio station (A, fig. 6-15) or the other radio station has an O-574/GRA (C, fig. 6-15), the AN/GSA-7 ringing feature (converting the switchboard 20 Hz ringing signal to a 1,600 Hz signal for transmission through the radio system and vice versa) can be used. For this reason, a radio operator at the AN/GSA-7 is not required as in the situations in (b) below. The operating procedures for two AN/GSA-7's in the system are given in c below. The operating procedures for AN/GSA-7 and O-574/GRA in the system are given in d below.

(b) When there is no AN/GSA-7 at one radio station (B, D, fig. 6-15), the automatic

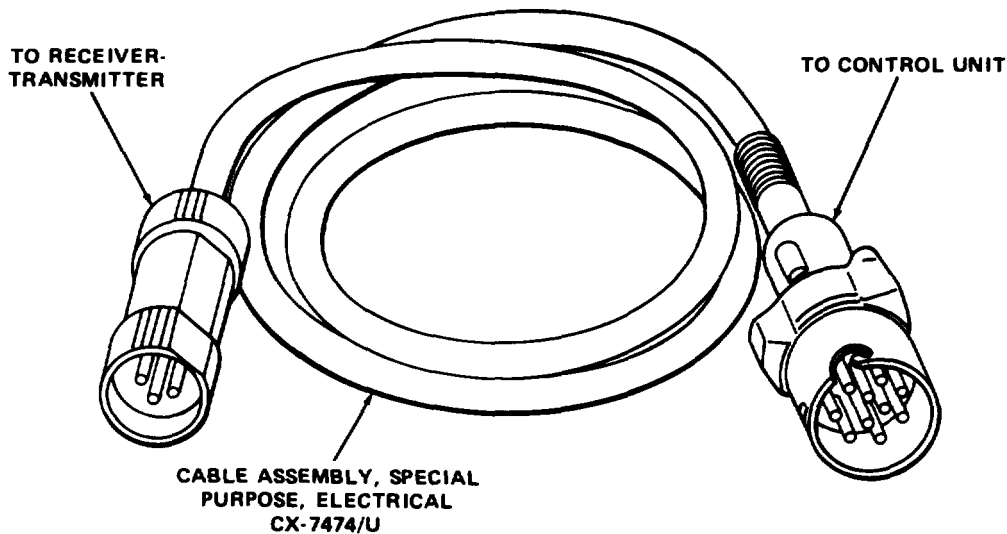

EL3YR040

Figure 6-14. Cable Assembly, Special Purpose, Electrical CX-7474/U.

ringing feature in the AN/GSA-7 through the radio system is no longer effective. Accordingly, either an operator is at the AN/GSA-7 to arrange with the switchboard operator for RWI (B, fig. 6-15; *d(1)* below) or a telephone next to the radio and connected to it through the switchboard is used by the switchboard operator to hear radio calls (D, fig. 6-15).

b. Connections. The following connections at the AN//GSA-7 are used whether there is a radio operator in the system (*c* below) or not (*d* below).

(1) Interconnect the AN/GSA-7 and RT-841/PRC-77 with the CX-7474/U (A, fig. 6-16). Do not connect the monitor telephone unless there is no radio operator at the AN/GSA-7 (*d(2)* below).

(2) Before using the O-574/GRA, install four Batteries, Dry BA-1312/U (fig. 6-13). Unlatch the spring-loaded clamps, and remove the front panel with the chassis attached. Install the four BA-1312/U batteries as shown in the diagram on the tubular battery case. The spring-loaded contact assembly in the bottom of the battery case will cause the top battery to protrude slightly. Screw on the threaded battery case cover completely. Replace the chassis in the case and tighten the spring-loaded clamps.

(3) Set the RT-841/PRC-77 function switch to ON. Tune in a desired radio station.

(4) Make the following adjustments on the AN/GSA-7:

(*a*) Connect the AN/GSA-7 to a power source (TM 11-5135-15).

(*b*) Set the OFF-AC-DC switch to AC or DC, depending on the power source.

(*c*) Connect the H-33/PT to the AUDIO connector.

(*d*) Set the monitor switch to T RADIO& MON. The rushing noise from the RT-841/PRC-77 should be heard.

(*e*) Connect the field wires from the switchboard to the AN/GSA-7 LINE binding posts. If the rushing noise ceases and beeps originating in the AN/GSA-7 are heard (indicating that the RT-841/PRC-77 has been keyed), transpose the field wires at the LINE binding posts. The rushing noise should return, and the beeps from the AN/GSA-7 should cease. If this does not occur, make the following checks:

1. Check to see that no switchboard cord is connected to the radio link jack (B, C, fig. 6-16).

2. Check to see that the field wires are not short-circuited.

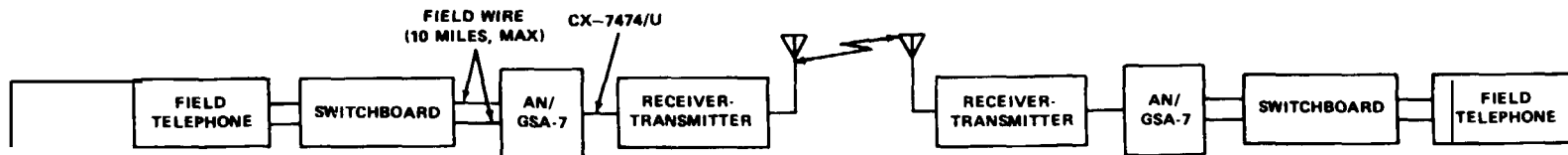

A. AN/GSA-7 AT BOTH STATIONS; RADIO OPERATOR NOT REQUIRED.

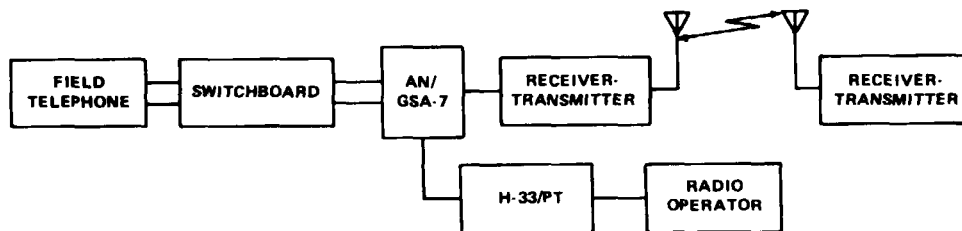

B. AN/GSA-7 AT ONE STATION; RADIO OPERATOR REQUIRED.

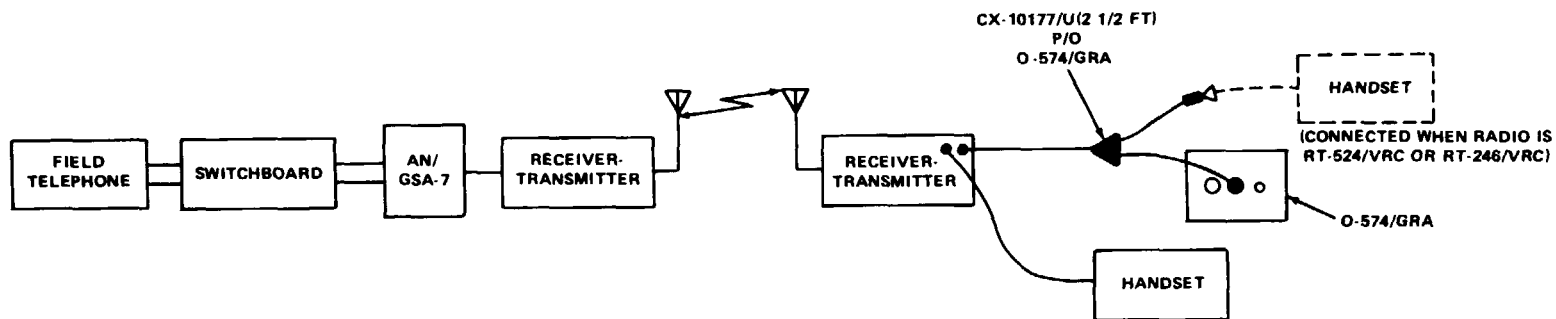

C. AN/GSA-7 AT ONE STATION, O-574/GRA AT OTHER; NO RADIO OPERATOR REQUIRED.

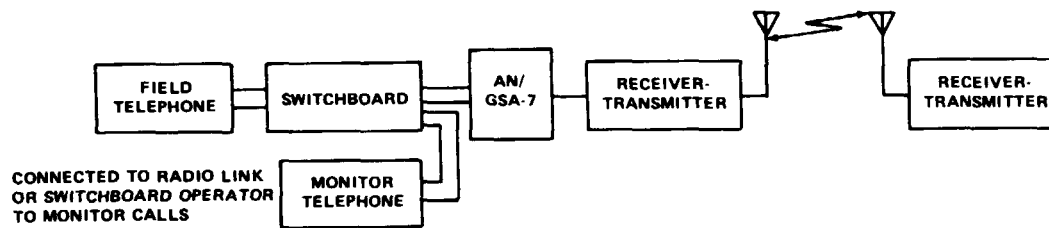

D. AN/GSA-7 AT ONE STATION, RADIO MONITOR TELEPHONE; NO OPERATOR REQUIRED.

EL3YR041

Figure 6-15. Arrangements for RWI with RT-841/PRC-77 and Radio Set Control AN/GSA-7.

(f) Proceed to check the operation of the radio with the H-33/PT.

(g) Use the procedures in *c* below when there are two AN/GSA-7's in the system, and those in *d* below when there is no other AN/GSA-7 in the system.

c. Two AN/GSA-7's in System. When there is an AN/GSA-7 at each radio station, no radio operator is required at the AN/GSA-7 that is connected to the RT-841/PRC-77 (A, fig. 6-15). Normal ringing between switchboard operators over the radio system can be used.

(1) Interconnect the AN/GSA-7 equipment (*b* above).

(2) At each AN/GSA-7, set the monitor switch to T RADIO&MON.

(3) Set the switch on each subscriber's telephone to LB operation.

(4) Switchboard and subscriber telephone operation may now proceed normally for radio operation. Use the hand generator (20 Hz) to call the distant switchboard; use push-to-talk radio operation with the proper radio call signs and radio procedures.

d. One AN/GSA-7 in System. When there is no AN/GSA-7 at the other radio station, there are three methods of providing RWI. In one arrangement ((1) below), a radio operator is stationed at the AN/GSA-7, to make the RWI arrangements with the switchboard operator (B, fig. 6-15). In a second arrangement ((2) below), a telephone at the switchboard is continuously connected to the radio system; the switchboard operator answers radio calls on this telephone and makes RWI connections, becoming a radio operator for the operation (D, fig. 6-15). In a third arrangement ((3) below), the distant radio station operator is provided with an O-574/GRA which will provide the 1,600 Hz signal to ring through an unattended AN/GSA-7 to call the switchboard (C, fig. 6-15).

(1) *Radio operator at AN/GSA-7.* These procedures require a radio operator at the AN/GSA-7.

(a) Interconnect the AN/GSA-7 equipment (*b* above).

(b) At the AN/GSA-7, set the monitor switch to T RADIO&MON position. Use the H-33/PT to communicate with the distant radio station.

(c) When RWI is required for communication with a switchboard subscriber, advise the distant radio station to stand by while the arrangements in 1 through 3 below are being made:

1. On the AN/GSA-7, hold the monitor switch at R TEL to ring the switchboard. Release the switch, and ask the switchboard operator for connection with the desired subscriber.

2. At the switchboard, the operator connects the operator's cord to the desired subscriber's jack, rings, advises the subscriber of the radio call, and the call signs, and asks him to ring back when the radio communication is completed.

3. The switchboard operator then connects the subscriber's cord to the radio link jack (B, fig. 6-16) and tells the radio operator that the subscriber is ready.

(d) At the AN/GSA-7, the radio operator sets the AN/GSA-7 monitor switch to T RADIO&MON position. Communication between the subscriber and the distant radio station proceeds automatically on push-to-talk operation. The radio operator at the AN/GSA-7 can monitor the communication.

(e) At the switchboard, the operator removes the operator's cord from the subscriber's jack during the subscriber-radio communication.

(f) when the subscriber rings off (the subscriber's signal indicator will indicate white), insert the operator's cord into the subscriber's jack and challenge the circuit without operating the headset-hestset switch to the push-to-talk *radio* position (this would key the radio).

(g) Remove the operator's and subscriber's cords when the subscriber-radio communication is finished.

(2) *No radio operator at AN/GSA-7.* When there is no radio operator available at the AN/GSA-7, a monitor telephone is connected at the switchboard to the radio link for listening for radio calls that require RWI connections.

(a) Interconnect the AN/GSA-7 equipment (*b* above).

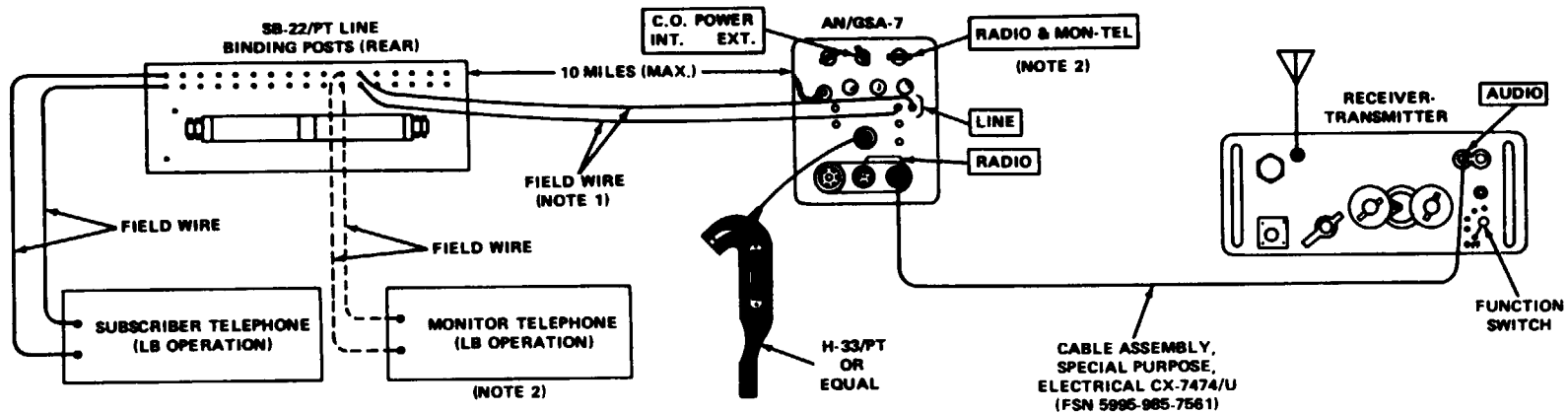

A. CONNECTIONS AND SWITCH POSITIONS.

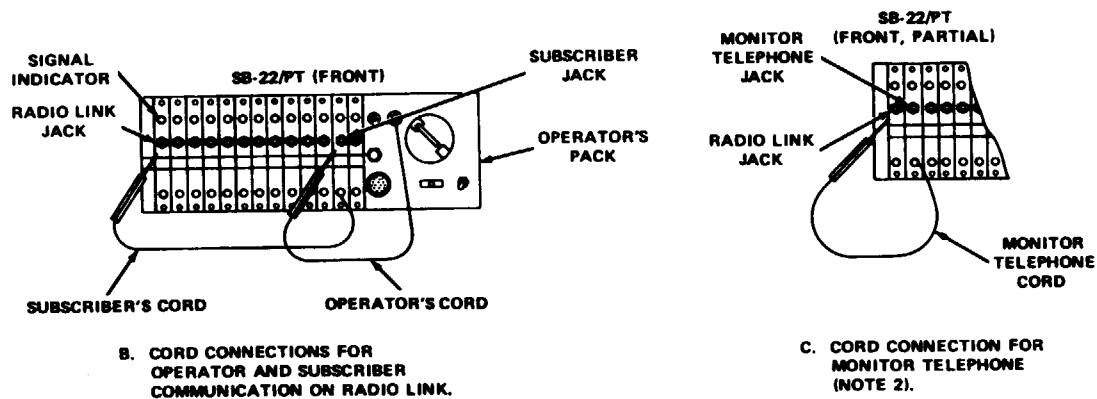

NOTES:

1. IF RECEIVER-TRANSMITTER IS KEYED, TRANSPOSE THESE CONNECTIONS AT SB-22/PT.
2. THE MONITOR TELEPHONE IS LOCATED AT SB-22/PT TO ENABLE SWITCHBOARD OPERATOR TO HEAR INCOMING RADIO CALLS ON THE HANDSET WHEN THERE IS NO OPERATOR AT THE AN/GSA-7.

EL3YR042

Figure 6-16. Radio Set Control AN/GSA-7 with RT-841/PRC-77 to Provide RWI; Connections and Control Settings.

(b) Connect a monitor telephone to the switchboard (A, fig. 6-16); set it for LB operation, and place the telephone handset so that the switchboard operator can hear radio calls. Connect the monitor telephone cord to the radio link jack (C, fig. 6-16).

(c) To communicate with the distant radio station, insert the operator's cord into the monitor telephone jack (C, fig. 6-16). Operate the switchboard handset-chestset switch to the push-to-talk *radio* position to key the radio and communicate with the distant radio station; use proper call signs and radio procedure.

(d) When a radio call is heard on the monitor telephone handset, use the monitor telephone to answer the call. When the desired subscriber has been determined, advise the distant radio station to stand by while the arrangements in 1 and 2 below are being made.

1. Insert the operator's cord into the subscriber's jack, ring, and advise the subscriber of the radio call and the call signs; ask him to ring back when the radio communication is finished.

2. Remove the monitor telephone cord from, and connect the subscriber's cord to, the radio link jack. Communication between the subscriber and distant radio station proceeds automatically with push-to-talk radio operation.

(e) Remove the operator's cord from the subscriber's jack.

(f) When the subscriber rings off (the subscriber's signal indicator will show white), insert the operator's cord into the subscriber's jack, and challenge the circuit without operating the headset-chestset switch to the push-to-talk radio position (this would key the radio).

(g) Remove the operator's cord from the subscriber's jack, and reconnect the monitor telephone cord to the radio link jack (C, fig. 6-16) to await further radio calls.

(3) *O-5741/GRA provided at radio.* When one radio is connected to the AN/GSA-7 and another radio is provided with the O-574/GRA-7 (C, fig. 6-15), operation can proceed as though there were two AN/GSA-7's in the system.

(a) Interconnect the AN/GSA-7 equipment (b above).

(b) Connect the O-574/GRA to the receiver-transmitter (C, fig. 6-15),

(c) When the radio operator with the O-574/GRA wishes to call the switchboard, he presses the RING switch on the O-574/GRA for a few seconds. The switchboard operator answers and makes the necessary connection to the subscriber.

(d) When the switchboard operator wishes to call a radio operator who is provided with an O-574/GRA, he can either ring or use the call sign on the radio link line. If the switchboard operator uses ringing to call, the O-574/GRA user must be aware of the 1,600 Hz buzz in his audio accessory, alerting him to a call from the switchboard operator.

6-9. Control Group AN/GRA-6

The AN/GRA-6 (TM 11-5038) may be used for remote radio control of the radio transmission and reception of the radio set at a separation of 2 miles (3.2 km, approximately) (a below). This equipment may also be used to provide RWI between Switchboard, Telephone SB-22/PT (TM 11-5805-262-12) and the radio set (b below). Cable Assembly, Special Purpose, Electrical CX-7474/U (NSN 5995-00-985-7561) (fig. 6-14) is required for the connection between the receiver-transmitter and Local Control C-434/GRC (A, fig. 6-20), Remote Control C-433/GRC is connected to the C-434/GRC with field wire.

a. Remote Radio Control.

(1) Connections.

(a) Install the batteries in the C-434/GRC and C-433/GRC units of the AN/GRA-6 (TM 11-5038).

(b) Place the C-434/GRC unit next to the RT-841/PRC-77 and interconnect the two units with the CX-7474/U (A, fig. 6-20).

(c) Connect a handset to the RT-841/PRC-77; it will be used by the radio operator for radio communication,

(d) Interconnect the C-434/GRC and C-433/GRC units with field wire.

(e) To check for proper connection of the field wire to the units, perform the following operations:

1. Turn on the RT-841/PRC-77 by setting the function switch to ON. A rushing noise should be heard on the handset.

2. At the C-434/GRC unit (local), set the REMOTE switch to SET 1.

WARNING

Voltages as high as 45 volts dc are present on the field wire when the radio is keyed from the remote control unit.

3. At the C-433/GRC unit (remote), set the SELECTOR switch to fully counterclockwise (for the left-hand write-in position). Operate the handset push-to-talk switch, and check to see that the RT-841/PRC-77 has been keyed. If it has not been keyed, release the push-to-talk switch and reverse the field wire connection to the LINE binding posts of either control unit. Recheck the keying of the RT-841/PRC-77.

(2) *Telephone operation between control units.* To prevent accidental keying of the radio by the C-433/GRC unit handset, always set the REMOTE switch on the C-434/GRC unit to TEL ONLY.

(a) To ring from either the C-434/GRC or C-433/GRC, crank the handle of the ringing generator.

(b) To communicate between the two control units, proceed as follows:

1. At the C-434/GRC, set the LOCAL switch to TEL; at the C-433/GRC, set the SELECTOR switch to TEL.

2. Remove the CX-7474/U from the C-434/GRC AUDIO connector, and replace it with an H-33/PT (or equivalent).

3. Communicate between the two control units using the associated handsets.

(3) *Radio communication.* Check to see that the CX-7474/U is connected between the C-434/GRC and the RT-841/PRC-77 (A, fig. 6-20).

(a) To communicate on the radio at the C-434/GRC, use the handset connected to the RT-841/PRC-77 (A, fig. 6-20).

(b) To communicate on the radio from the C-433/GRC, proceed as follows:

1. At the C-434/GRC, set the REMOTE switch to SET 1.

2. At the C-433/GRC, set the SELECTOR switch fully counterclockwise ((1) (e) 3 above).

3. Operate the H-33/PT at the C-433/GRC to communicate on the radio using push-to-talk

radio operation with the proper call signs and radio procedure.

b. *RWI Operation.*

(1) *Connections.*

(a) Install batteries in the C-434/GRC and C-433/GRC (TM 11-5038).

(b) Locate the C-434/GRC beside the RT-841/PRC-77 and interconnect the two units with the CX-7474/U (B, fig. 6-20).

(c) Locate the C-433/GRC beside the switchboard, and interconnect the C-434/GRC and C-433/GRC and the SB-22/PT with field wire.

(d) Position a monitor telephone next to the switchboard, and connect it to one of the line binding posts of the switchboard.

(e) To check for proper connection of the field wire, perform the following operations:

1. Turn on the RT-841/PRC-77 by setting the function switch to ON. Connect a handset to the RT-841/PRC-77; a rushing noise from the radio should be heard.

2. At the C-434/GRC, set the REMOTE switch to SET 1.

3. At the C-433/GRC, set the SELECTOR switch fully counterclockwise (for the left-hand write-in position).

4. At the C-433/GRC, connect an H-33/PT to the AUDIO connector (B, fig. 6-20); tape the push-to-talk switch of the handset so that it is always operated.

5. At the switchboard, connect the operator's cord to the radio link jack and operate the switch on the operator's headset-chestset to the push-to-talk radio position to key the radio. If the radio is not keyed, release the switch and reverse the connections of the field wire to the switchboard binding posts. Recheck the keying of the radio with the switchboard operator's set.

(f) Connect the monitor telephone cord to the radio link jack (D, fig. 6-20); set it for LB operation, and place the telephone handset so that the switchboard operator can hear radio calls.

(2) *Operation.* The monitor telephone connected at the switchboard to the radio link will be used by the operator to hear incoming radio calls requiring RWI.

(a) To communicate on the radio from the RT-841/PRC-77, use the handset connected to the radio.

(b) To use the telephone circuit between the C-434/GRC and the C-433/GRC, connect the H-33/PT to the C-434/GRC in place of the CX-7474/U and use the procedures in *a(2)* above.

(c) For the switchboard operator to communicate on the radio, proceed as follows:

1. Connect the operator's cord to the radio link jack.

2. Use the push-to-talk radio position of the handset-chestset switch to key the radio, and release the switch to receive the radio communication.

(d) When the radio call is heard on the monitor radio, insert the operator's cord into the monitor telephone jack. When the desired subscriber has been determined, advise the distant station to stand by while the arrangements in *1* and *2* below are being made.

1. Insert the operator's cord into the subscriber's jack, and advise the subscriber of the radio call and call signs; request him to ring back when the radio communication is completed.

2. Remove the monitor telephone cord (D, fig. 6-20) from, and connect the subscriber's cord to, the radio link jack (C, fig. 6-20). Communication between the subscriber and distant station proceeds automatically with push-to-talk radio operation.

(e) Remove the operator's cord from the subscriber's jack.

(f) When the subscriber rings off (the subscriber's signal indicator will show white), insert the operator's cord into the subscriber's jack and challenge the circuit without operating the headset-chestset switch to push-to-talk RADIO position (this would key the radio).

(g) Remove the operator's cord from the subscriber's jack, and reconnect the monitor telephone cord to the radio jack (D, fig. 6-20) to await further radio calls.

6-10. Pack Frame LC-2

Pack Frame LC-2 (fig. 6-17) is used to carry the radio.

NOTE

Refer to FM 21-15 (Care and Use of Individual Clothing and Equipment) for other details on Pack Frame LC-2, which is for existence loads carried by ground troops.

a. Components (fig. 6-17). The following items are required for radio installation. See appendix D (additional authorization list) for stock numbers.

(1) *Pack Frame LC-2.*

(a) Frame, Pack, Ground Troops, Light-weight.

(b) Left and right shoulder straps; each strap is provided with a quick-release buckle.

(c) Lower back strap.

(d) Waist strap; provided with a quick-release buckle.

(2) *Shelf, Cargo Support.* The shelf is attached to the pack frame to hold the radio (and other equipment, as required).

(3) *Straps, Webbing, Cargo Tie Down, Light-weight Pack Frame.* Two straps are required. They are used to hold the radio to the pack frame.

b. Installation (fig. 6-17). The following instructions do not include attachment and adjustment of shoulder, waist, and lower back straps on the pack frame; see FM 21-15 and paragraph 2-5, *b* for this information.

(1) Attach the cargo shelf to the pack frame by hooking it to the center brace (A, fig. 6-18).

(2) Position the radio on the cargo shelf and wrap the tiedown straps around the radio (B, fig. 6-18). Tighten the strap fasteners.

(3) Pull up on the end of the strap to open the strap fastener and loosen the strap.

c. Radio Equipment. Install the desired antenna (para 2-6) on the radio.

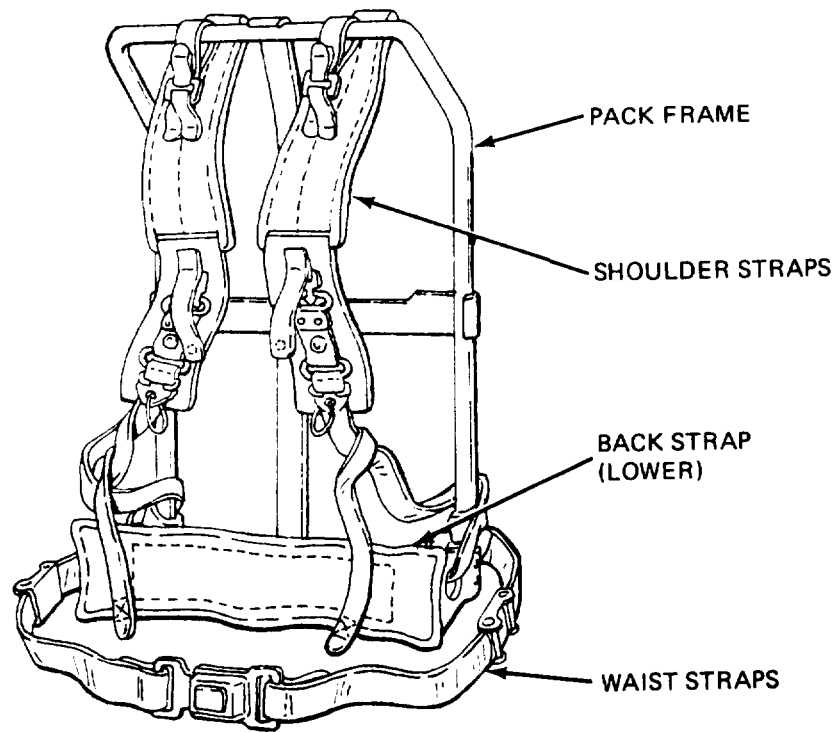

A. PACK FRAME LC-2

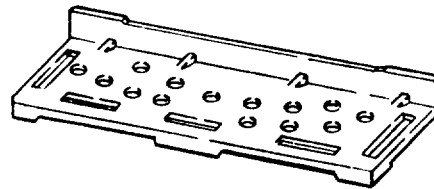

B. SHELF, CARGO SUPPORT

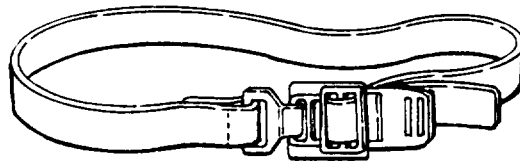

C. CARGO TIE DOWN STRAP

EL3YR011

Figure 6-17. Pack Frame LC-2, Components.

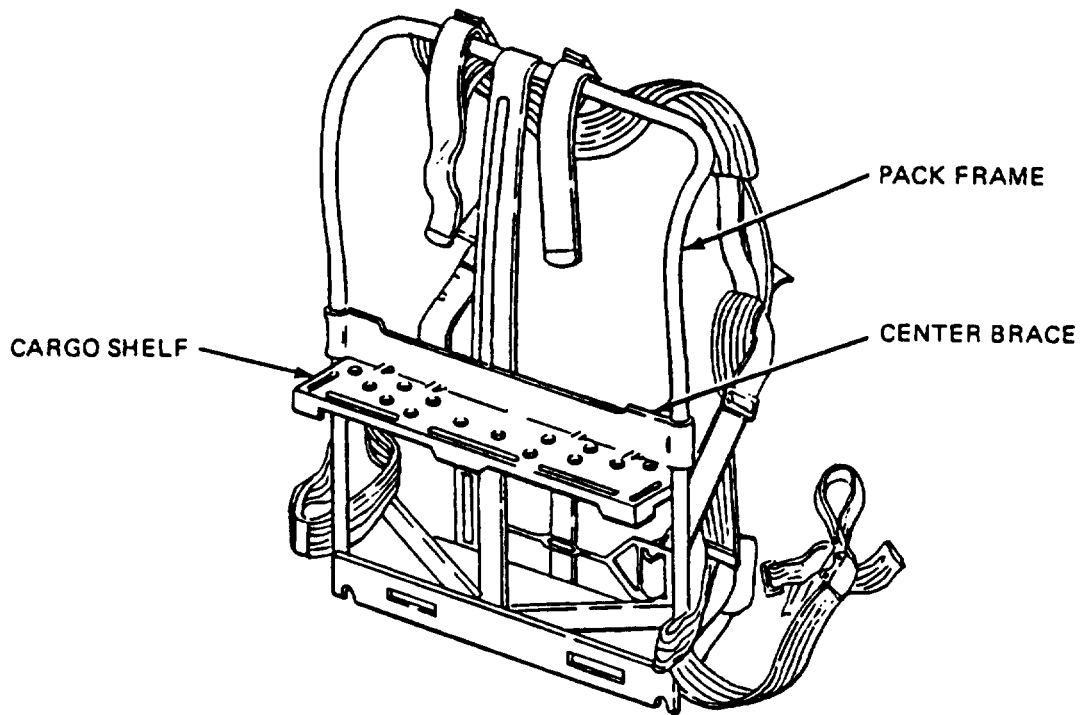

A. INSTALL CARGO SHELF

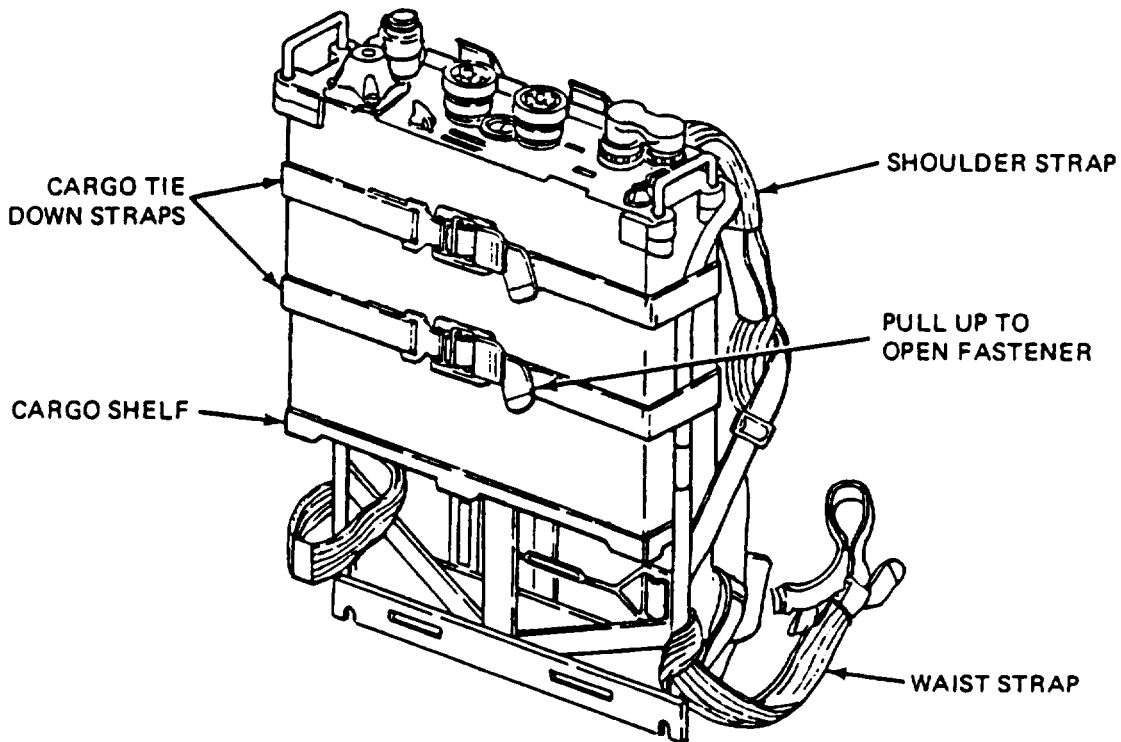

B. INSTALL RADIO

EL3YR012

Figure 6-18. Installation of Radio on Pack Frame LC-2.

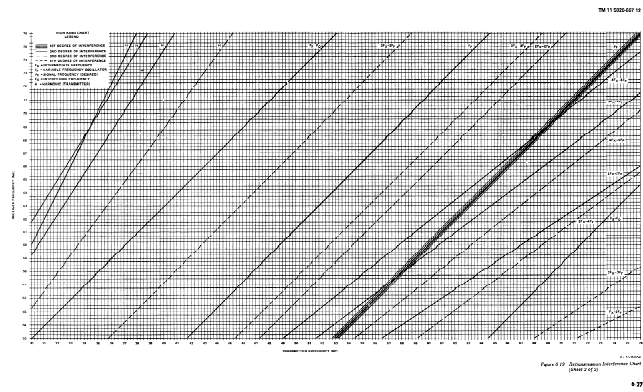

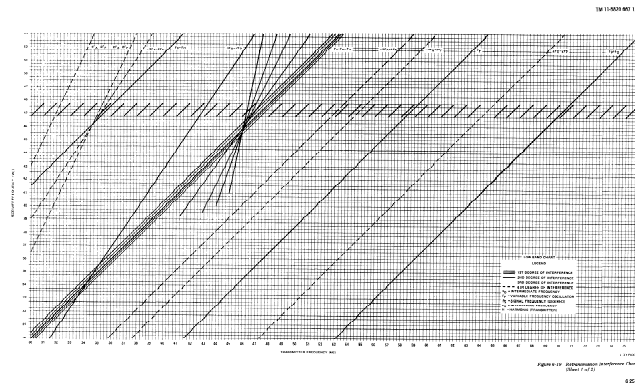

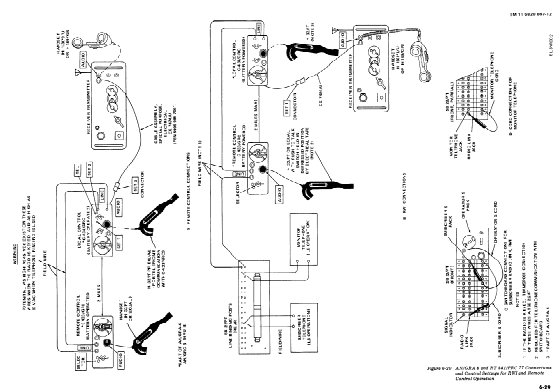

APPENDIX A

REFERENCES

<p>AR 55-38 DA Form 2028 DA Form 2062 DA Pam 25-30 DA Pam 738-750 FM 21-15 SB 11-6 SB 11-573</p>	<p>Reporting of Transportation Discrepancies in Shipments. Recommended Changes to Publications and Blank Forms. Hand Receipt/Annex Number. Consolidated Index of Army Publications and Blank Forms. The Army Maintenance Management System (TAMMS). Care and Use of Individual Clothing and Equipment. FSC Class 6135: Primary Battery Supply Data. Painting and Preservation Supplies Available for Field Use for Electronics Command Equipment.</p>
<p>SB 11-623 SF 361 SF 364 SF 368 TB 43-0129</p>	<p>Requisitioning of Test Set, Battery AN/PSM-13. Transportation Discrepancy Report (TDR) Report of Discrepancy (ROD). Product Quality Deficiency Report (Category II). Safety Measures to be Observed When Installing and Using Whip Antennas, Field-Type Masts, Towers and Antennas and Metal Poles That are Used with Communications, Radar and Direction Finder Equipment. Field Instructions for Painting and Preserving Electronics Equipment.</p>
<p>TB 43-0118</p>	<p>Field Instructions for Painting and Preserving Electronics Equipment.</p>
<p>TM 11-284 TM 11-285 TM 11-286 TM 11-290</p>	<p>Radio Sets AN/GRC-3, -4, -5,-6,-7 and -8. Radio Set AN/VRC-7. Radio Sets AN/VRC-8, AN/VRC-9 and AN/VRC-10. Field Maintenance: Receiver-Transmitters RT-70/GRC, RT-70A/GRC and Radio-Receiver-Transmitter RT-70B/GRC.</p>
<p>TM 11-291 TM 11-296</p>	<p>Radio Sets AN/VRC-13, AN/VRC-14 and AN/VRC-15. Operator's and Organizational Maintenance Manual (Including Repair Parts and Special Tools List) for Radio Set AN/PRC-6.</p>
<p>TM 11-611 TM 11-642 TM 11-5038 TM 11-5135-15 TM 11-5805-262-12</p>	<p>Radio Sets, AN/VRC-16, AN/VRC-17 and AN/VRC-18. Radio Sets, AN/VRC-20, AN/VRC-21 and AN/VRC-22. Control Group AN/GRA-6. Radio Set Control AN/GSA-7 (NSN 5820.00-543-1397). Operator's and Organizational Maintenance Manual for Switchboards, Telephone Manual SB-22/PT (NSN 5805-00-257-3602) and SB-22A/PT (5805-00-715-6171) (Including Tone Signaling Adapter TA-977/PT) (5805-01-040-9653).</p>
<p>TM 11-5820-292-10 TM 11-5820-348-15</p>	<p>Operator's Manual: Radio Sets AN/PRC-8, -8A, -9, -9A, -10, -10A and -28. Organizational, Direct Support, General Support, and Depot Maintenance Manual: Antenna Equipment RC-292 (NSN 5985-00-497-8554),</p>

- TM 11-5820-398-12 Operator's and Organizational Maintenance Manual (Including Repair Parts and Special Tools Lists) Radio Set AN/PRC-25 (NSN 5820-00-857-0759) (Including Receiver-Transmitter, Radio RT-505/PRC-25) (5820-00-857-0934).
- TM 11-5820-401-10-1 Operator's Manual for Radio Sets AN/VRC-12 (NSN 5820-00-223-7412), AN/VRC-43 (5820-00-223-7415), AN/VRC-45 (5820-00-223-7418), AN/VRC-46 (5820-00-223-7433), AN/VRC-47 (5820-00-223-7434), AN/VRC-48 (5820-00-223-7435) and AN/VRC-49 (5820-00-223-7437) (Used Without an Intercom Set).
- TM 11-5820-401-10-2 Operator's Manual: Radio Sets AN/VRC-12 (NSN 5820-00-223-7412), AN/VRC-43 (5820-00-223-7415), AN/VRC-44 (5820-00-223-7417), AN/VRC-45 (5820-00-223-7418), AN/VRC-46 (5820-00-223-7433), AN/VRC-47 (5820-00-223-7434), AN/VRC-48 (5820-00-223-7435) and AN/VRC-49 (5820-00-223-7437) (Used With an Intercom System).
- TM 11-5820-401-20-1 Organizational Maintenance Manual for Radio Sets AN/VRC-12 (NSN 5820-00-223-7412), AN/VRC-43 (5820-00-223-7415), AN/VRC-44 (5820-00-223-7417), AN/VRC-45 (5820-00-223-7418), AN/VRC-46 (5820-00-223-7433), AN/VRC-47 (5820-00-223-7434), AN/VRC-48 (5820-00-223-7435) and AN/VRC-49 (5820-00-223-7437) (Used Without Intercom Set).
- TM 11-5820-401-20-2 Organizational Maintenance Manual for Radio Sets AN/VRC-12 (NSN 5820-00-223-7412), AN/VRC-43 (5820-00-223-7415), AN/VRC-44 (5820-00-223-7417), AN/VRC-45 (5820-00-223-7418), AN/VRC-46 (5820-00-223-7433), AN/VRC-47 (5820-00-223-7434), AN/VRC-48 (5820-00-223-7435) and AN/VRC-49 (5820-00-223-7437) (Used With Intercom System AN/VIC-1(V)).
- TM 11-5820-477-12 Operator's and Organizational Maintenance Manual: Radio Set Control Groups AN/GRA-39 (NSN 5820-00-889-3860), AN/GRA-39A (5820-00-082-3998) and AN/GRA-39B (5820-00-949-9909).
- TM 11-5820-498-12 Operator's and Organizational Maintenance Manual: Radio Sets, AN/VRC-53 (NSN 5820-00-223-7467), AN/VRC-64 (5820-00-223-7475), AN/GRC-125 (5820-00-223-7411) and AN/GRC-160 (5820-00-223-7473), and Amplifier-Power Supply Groups OA-3633/GRC and OA-3633A/GRC (5820-00-973-3383).
- TM 11-5820-549-12 Operator's and Organizational Maintenance Manual: Receiving Set, Radio AN/PRR-9 and Transmitting Sets, Radio AN/PRT-4 and AN/PRT-4A.
- TM 11-5820-667-12-HR Hand Receipt Manual Covering End Item/Components of End Item (COEI), Basic Issue Items (BII) and Additional Authorization Lists (AAL) for Radio Set AN/PRC-77 (NSN 5820-00-930-3724).
- TM 11-5820-667-20P Organizational Maintenance Repair Parts and Special Tools List for Radio Set, AN/PRC-77 (NSN 5820-00-930-3724).
- TM 11-5820-670-12 Operator's and Organizational Maintenance Manual for Radio Set AN/ARC-131 (NSN 5821-00-937-4686).
- TM 11-5820-713-15 Operator's, Organizational, Direct Support, General Support and Depot Maintenance Manual: Radio Terminal Set AN/GRC-163 (NSN 5820-00-832-5617).
- TM 11-5820-882-10 Operator's Manual: Radio Set AN/PRC-68 (NSN 5820-01-079-9260).
- TM 11-5821-204-12 Operator's and Organizational Maintenance Manual for Radio Set AN/ARC-44.
- TM 11-5821-244-12 Operator's and Organizational Maintenance Manual for Radio Set AN/ARC-54 (NSN 5821-00-082-3598).
- TM 11-6140-203-14-1 Operator's, Organizational, Direct Support and General Support Maintenance Manual for Aircraft and Nonaircraft Nickel-Cadmium Batteries (General).
- TM 11-6625-3052-14 Operator's, Organizational, Direct Support and General Support Maintenance Manual for Multimeter, Digital AN/PSM-45 (NSN 6625-01-132-2512).
- TM 11-6625-450-15 Organizational, Direct Support, General Support and Depot Maintenance Manual Including Repair Parts. Battery Testers TS-183/U, TS-183A/U and TS-183B/U.

APPENDIX B

MAINTENANCE ALLOCATION

Section I. INTRODUCTION

B-1. General

This appendix provides a summary of the maintenance operations for the AN/PRC-77. It authorizes categories of maintenance for specific maintenance functions on repairable items and components and the tools and equipment required to perform each function. This appendix may be used as an aid in planning maintenance operations.

B-2. Maintenance Function

Maintenance functions will be limited to and defined as follows:

a. Inspect. To determine the serviceability of an item by comparing its physical, mechanical, and/or electrical characteristics with established standards through examination.

b. Test. To verify serviceability and to detect incipient failure by measuring the mechanical or electrical characteristics of an item and comparing those characteristics with prescribed standards.

c. Service. Operations required periodically to keep an item in proper operating condition; i.e., to clean (decontaminate), to preserve, to drain, to paint, or to replenish fuel, lubricants, hydraulic fluids, or compressed air supplies.

d. Adjust. To maintain, within prescribed limits, by bringing into proper or exact position, or by setting the operating characteristics to the specified parameters.

e. Align. To adjust specified variable elements of an item to bring about optimum or desired performance.

f. Calibrate. To determine and cause corrections to be made or to be adjusted on instruments or test measuring and diagnostic equipments used in precision measurement. Consists of comparisons of two instruments, one of

which is a certified standard of known accuracy, to detect and adjust any discrepancy in the accuracy of the instrument being compared.

g. Install. The act of emplacing, seating, or fixing into position an item, part, module (component or assembly) in a manner to allow the proper functioning of the equipment or system.

h. Replace. The act of substituting a serviceable like type part, subassembly, or module (component or assembly) for an unserviceable counterpart.

i. Repair. The application of maintenance services (inspect, test, service, adjust, align, calibrate, replace) or other maintenance actions (welding, grinding, riveting, straightening, facing, remachining, or resurfacing) to restore serviceability to an item by correcting specific damage, fault, malfunction, or failure in a part, subassembly, module (component or assembly), end item, or system.

j. Overhaul. That maintenance effort (service/action) necessary to restore an item to a completely-serviceable/operational condition as prescribed by maintenance standards (i.e., DMWR) in appropriate technical publications. Overhaul is normally the highest degree of maintenance performed by the Army. Overhaul does not normally return an item to like new condition.

k. Rebuild. Consists of those services/actions necessary for the restoration of unserviceable equipment to a like new condition in accordance with original manufacturing standards. Rebuild is the highest degree of materiel maintenance applied to Army equipment. The rebuild operation includes the act of returning to zero those age measurements (hours, miles, etc.) considered in classifying Army equipments/components.

B-3. Column Entries

a. Column 1, Group Number. Column 1 lists group numbers, the purpose of which is to identify components, assemblies, subassemblies, and modules with the next higher assembly.

b. Column 2, Component/Assembly. Column 2 contains the noun names of components, assemblies, subassemblies, and modules for which maintenance is authorized.

c. Column 3, Maintenance Functions. Column 3 lists the functions to be performed on the item listed in column 2. When items are listed without maintenance functions, it is solely for purpose of having the group numbers in the MAC and RPSTL coincide.

d. Column 4, Maintenance Category. Column 4 specifies, by the listing of a "work time" figure in the appropriate subcolumn(s), the lowest level of maintenance authorized to perform the function listed in column 3. This figure represents the active time required to perform that maintenance function at the indicated category of maintenance. If the number or complexity of the tasks within the listed maintenance function vary at different maintenance categories, appropriate "work time" figures will be shown for each category. The number of task-hours specified by the "work time" figure represents the average time required to restore an item (assembly, subassembly, component, module, end item or system) to a serviceable condition under typical field operating conditions. This time includes preparation time, troubleshooting time, and quality assurance/quality control time in addition to the time required to perform the specific tasks identified for the maintenance functions authorized in the maintenance allocation chart. Subcolumns of column 4 are as follows:

- C – Operator/Crew
- O – Organizational

- F – Direct Support
- H – General Support
- D – Depot

e. Column 5, Tools and Equipment. Column 5 specifies by code, those common tool sets (not individual tools) and special tools, test, and support equipment required to perform the designated function.

f. Column 6, Remarks. Column 6 contains an alphabetic code which leads to the remark in section IV, Remarks, which is pertinent to the item opposite the particular code.

B-4. Tool and Test Equipment Requirements (Sec III)

a. Tool or Test Equipment Reference Code. The numbers in this column coincide with the numbers used in the tools and equipment column of the MAC. The numbers indicate the applicable tool or test equipment for the maintenance functions.

b. Maintenance Category. The codes in this column indicate the maintenance category allocated the tool or test equipment.

c. Nomenclature. This column lists the noun name and nomenclature of the tools and test equipment required to perform the maintenance functions.

d. National/NATO Stock Number. This column lists the National/NATO stock number of the specific tool or test equipment.

e. Tool Number. This column lists the manufacturer's part number of the tool followed by the Federal Supply Code for manufacturers (5-digit) in parentheses.

B-5. Remarks (Sec IV)

a. Reference Code. This code refers to the appropriate item in section H, column 6.

b. Remarks. This column provides the required explanatory information necessary to clarify items appearing in section II.

(Next printed page is B-3)

Section II. MAINTENANCE ALLOCATION CHART
FOR RADIO SET AN/PRC-77

(1) Group number	(2) Component/Assembly	(3) Maintenance function	(4) Maintenance category					(5) Tools and eqpt	(6) Remarks	
			C	O	F	H	D			
00	Radio Set AN/PRC-77	Inspect	0.1						A	
		Test	0.1							
		Test		0.2				24, 25		B
		Service	0.1							C
		Repair	0.1	0.1				2		D
		Repair					4 thru	E,G		
		Overhaul					20.0	24, 25		
01	Antenna AT-271A/PRC	Inspect	0.1						F I S	
		Replace	.05							
		Repair		0.2				2		
02	Harness, Electrical Equipment LC-2	Inspect	0.1						F I H	
		Replace	0.1			0.5				
		Repair								
03	Bag, Cotton Duck CW-503/ PRC-25	Inspect	0.1						F I H	
		Repair	0.1			0.5				
04	Handset H-189/GR (See TM 11-5965-280-15 for Maintenance Allocation) or H-250/U	Replace		0.1					U	
05	Receiver-Transmitter RT-841/ PRC-77	Inspect	0.1						F A	
		Test	0.1							
		Test		0.25		0.5		1,2,23 3 thru 12,17, 18, 26, 27		
		Test					1.0	4 thru 19, 26, 27		
		Test					2.0	6 thru 12, 15 thru 22		
		Service	0.1			1.0		3,4,8,9, 11,12		
		Align					1.5	4 thru 19		
		Align					2.0	6 thru 12, 15 thru 22		
		Replace			0.1			2		J
		Repair			0.1			2		
Repair				0.5		3 thru 12				
		Repair				1.5	4 thru 19	O K		
		Repair				2.0	6 thru 12, 15 thru 22			
		Overhaul					20.0	L		

**MAINTENANCE ALLOCATION CHART
FOR RADIO SET AN/PRC-77 - Continued**

(1) Group number	(2) Component/Assembly	(3) Maintenance function	(4) Maintenance category					(5) Tools and eqpt	(6) Remarks
			C	O	F	H	D		
0501	Battery Box CY-2562/ PRC-25 (A100)	Inspect	0.1						F I M
		Replace	0.05						
		Repair		0.25				11,12	
		Repair			0.5				
0502	Front Panel Assembly (A300 (Includes Antenna Loading Network (A28))	Test			0.25				P N R
		Test				0.25			
		Test					0.25		
		Replace				1.0		11,12	
		Repair				0.25		5,11,12	
		Repair				1.2		5,11,12	
	Repair					0.75	5,11,12		
	Overhaul					3.0	5,11,12		
0503	Chassis Assembly (A200)	Repair			0.25			11,12	T Q
		Repair				0.5		11,12	
		Repair					1.5	11,12	

Section III. TOOL AND TEST EQUIPMENT REQUIREMENTS FOR RADIO SET AN/PRC-77

Tool or Test Equipment Ref Code	Maintenance Category	Nomenclature	National/NATO Stock Number	Tool Number
1	O	Multimeter AN/URM-105 or AN/PSM-45	6625-00-581-2036 6625-01-139-2512	
2	O	Tool Kit, Electronic Equipment TK-101/G	6180-00-064-5178	
3	F	Standard Items of Supply and Items to be Fabricated by Direct Support Maintenance Shops in accordance with TM 11-5820-677-35		
4	F,H,D	Test Set, RF Power AN/URM-120 or AN/GRM-114A	6625-00-813-8430 6625-01-114-4481	
5	F,H,D	Multimeter TS-352B/U or AN/PSM-45	6625-00-553-0142 6625-01-139-2512	
6	F,H,D	Signal Generator AN/URM-103 or AN/GRM-114A	6625-00-868-8352 6625-01-114-4481	
7	F,H,D	Voltmeter AN/URM-145	6625-00-973-3986	
8	F,H,D	Counter, Electronic AN/USM-207 or AN/USM-459	6625-00-911-6368 6625-01-061-8928	
9	F,H,D	Multimeter ME-26B/U or AN/USM-486	6625-00-646-9409 6625-01-145-2430	
10	F,H,D	-Power supply PP-3514/U	6130-00-445-6933	
11	F,H,D	Tool Kit, Electronic Equipment TK-100/G	5180-00-605-0079	
12	F,H,D	Tool Kit, Electronic Equipment TK-105/G	5180-00-610-8177	
13	H,D	Standard Items of Supply and Items to be Fabricated by General Support Maintenance Shops in accordance with TM 11-5820-667-35		
14	H,D	Capacity Meter ZM-3/U	6625-00-229-1060	
15	H,D	Signal Generator AN/URM-127 or AN/GRM-114A	6625-00-783-5965 6625-01-114-4481	
16	H,D	Voltmeter ME-30E/U or AN/USM-486	6625-00-420-9354 6626-01-145-2430	
17	F,H,D	Meter, Modulation ME-57/U or AN/GRM-114A	6625-00-647-3737 6625-01-114-4481	
18	F,H,D	Analyzer, Spectrum TS-723B/U or AN/GRM-114A	6626-00-668-9418 6625-01-114-4481	

**TOOL AND TEST EQUIPMENT REQUIREMENTS
FOR RADIO SET AN/PRC-77 - Continued**

Tool or Test Equipment Ref Code	Maintenance category	Nomenclature	National/NATO Stock Number	Tool Number
19	H,D	Oscilloscope AN/USM-281A or AN/USM-488	6625-00-228-2201 6625-01-187-7847	
20	D	Signal Generator AN/USM-44 or SG-1170/U	6626-00-669-4031 6625-01-120-3501	
21	D	Standard Items of Supply and Items to be Fabricated by Depot in accordance with TM 11-6820467-96 Peripheral Test Equipment		
22	D	Depot Support Shops and Facilities		
23	O	Test Set AN/PSM-13 (with Adapter U-410)	6625-00-868-8344	
24	O	Test Set, Radio AN/PRM-34	6625-01-094-5646	
25	O,D	Test Set, Power TS-2609/U		
26	F,H,D	Adapter UG-201A/G	5936-00-259-0205	
27	F,H,D	Adapter UG-274B/G	6935-00-926-7523	

Section IV. REMARKS

Reference Code	Remarks
A	Operational Tests.
B	Clean and Replace Battery.
C	Replacement of Antennas AT-892/PRC-25, AT-271A/PRC, and Support AB-591/PRC-25.
D	Replacement of Component Parts of Complete Radio Set.
E	Overhaul by Components.
F	Included in Inspection Time for Overall Radio Set.
G	Repair by Replacement of Components.
H	Quartermaster Repair.
I	Replaced by Operator; Part is Obtained from Organization Level.
J	Clean.
K	Replacement of Modules and Selected Parts.
L	Overhaul by Assemblies, Subassemblies, etc.
M	Replacement of Pressure Relief Valve.
N	Replacement of Loading Network, Selector Mechanism.
O	Replacement of Battery Connector Gasket and O-Ring, and Case Assembly.
P	Replacement of Pilot Light, Knobs, Connector Covers, Other Selected Parts.
Q	Replacement of Chassis-Mounted Parts.
R	All Repairs.
S	Replacement of Antenna Tip Cap, Antenna Assembly.
T	Replacement of Battery Connector.
U	H-250/U Handset Nonrepairable.

APPENDIX C

COMPONENTS OF END ITEM LIST

Section I. INTRODUCTION

C-1. scope

This appendix lists integral components of and basic issue items for Radio Set AN/PRC-77 to help you inventory items required for safe and efficient operation.

C-2. General

The Components of End Item List is divided into the following sections:

a. Section II. Integral Components of the End Item. These items, when assembled, comprise the AN/PRC-77 and must accompany it whenever it is transferred or turned in. The illustration will help you identify these items.

b. Section III. Basic Issue Items. Not applicable.

C-3. Explanation of Columns

a. Illustration. This column is divided as follows:

(1) *Figure number.* Indicates the figure number of the illustration on which the item is shown.

(2) *Item number.* Not used.

b. National Stock Number. Indicates the National stock number assigned to the item and which will be used for requisitioning.

c. Description. Indicates the Federal item name and, if required, a minimum description to identify the item. The part number indicates the primary number used by the manufacturer, which controls the design and characteristics of the item by means of its engineering drawings, specifications, standards, and inspection requirements to identify an item or range of items. Following the part number, the federal supply code for manufacturers (FSCM) is shown in parentheses.

d. Location. Not used.

e. Usable on Code. Not used.

f. Quantity Required (Qty Req'd). This column lists the quantity of each item required for a complete major item.

g. Quantity. This column is left blank for use during an inventory. Under the Rcv'd column, list the quantity you actually received on your major item. The Date columns are for your use when you inventory the major item.

(Next printed page is C-2)

Section II. INTEGRAL COMPONENTS OF END ITEM

(1) Illustration		(2) National Stock Number	(3) Description Part Number (FSCM)	(4) Location	(6) Usable on Code	(6) Qty Reqd	(7) Quantity	
(A) Fig. No.	(B) Item No.						Rcvd	Date
1-2		5820-00-930-3724	Radio Set AN/PRC-77			1		—
1-2		5820-00-242-4967	Antenna 271A/PRC (80063			1		
1-2		5820-00-889-3803	Antanna 892/PRC-25 (80063			1		
1-2		6140-00-952-1798	Battery Box CY-2562/PRC-25 (80063			1		
1-2		5965-00-069-8886	Handset H-189/GR (80063			1		
1-2		5965-00-043-3463	Handset H-250/U (80063			1		
1-2		5820-00-930-3725	Receiver-Transmitter, Radio (80063 RT-841/PRC-77			1		
1-2		5820-00-086-7149	Support, Antenna (80063 AB-591/PRC			1		
1.2		5820-00-086-7138	Bag, Cotton Duck (80063: CW-503/PRC-25			1		

APPENDIX D

ADDITIONAL AUTHORIZATION LIST

Section I. INTRODUCTION

D-1. Scope

This appendix lists additional items you are authorized for the support of the AN/PRC-77.

D-2. General

This list identifies items that do not have to accompany the AN/PRC-77 and that do not have to be turned in with it. These items are all authorized to you by CTA, MTOE, TDA, or JTA.

D-3. Explanation of Listing

National stock numbers, descriptions, and quantities are provided to help you identify and request the additional items you require to support this equipment. The items are listed in alphabetical sequence by item name under the type document (i.e., CTA, MTOE, TDA, or JTA) which authorizes the item(s) to you.

(Next printed page is D-2)

Section II. ADDITIONAL AUTHORIZATION LIST

(1) National Stock Number	(2) Description	(3) Unit of Meas	(4) Qty Auth
	Part Number and FSCM		
	Usable On Code		
6135-00-926-8322	Battery, Dry BA-4386/U (80058)	EA	1
6135-01-034-2239	Battery, Lithium BA-5598/U	EA	2
6140-01-184-1460	Battery, Rechargeable, Ni/Cd BB-586/U	EA	2
6130-01-041-3490	Charger PP-7286/U	EA	1
8465-01-073-8326	Pack Frame LC-2 (81349) Consisting of:	EA	1
8465-00-001-6476	Shelf, Cargo Support (81349)	EA	1
8465-00-001-6477	Strap, Webbing, Cargo Tie Down, Lightweight Pack Frame (81349)	EA	2

APPENDIX E

EXPENDABLE SUPPLIES AND MATERIALS LIST

Section I. INTRODUCTION

E-1. Scope

This appendix lists expendable supplies and materials you will need to operate and maintain the AN/PRC-77. These items are authorized to you by CTA 50-970, Expendable Items (Except Medical, Class V, Repair Parts, and Heraldic Items).

E-2. Explanation of Columns

a. Column 1 — Item Number. This number is assigned to the entry in the listing and is referenced in the narrative instructions to identify the material (e.g., “Use cleaning compound, item 5, App. D”).

b. Column 2 — Level. This column identifies the lowest level of maintenance that requires the listed item.

- C – Operator/Crew
- O – Organizational Maintenance/Aviation Unit Maintenance

F – Direct Support Maintenance/Aviation Intermediate Maintenance

H – General Support Maintenance

c. Column 3 — National Stock Number. This is the National stock number assigned to the item; use it to request or requisition the item.

d. Column 4 — Description. Indicates the Federal item name and, if required, a description to identify the item. The last line for each item indicates the Federal Supply Code for Manufacturer (FSCM) in parentheses followed by a part number.

e. Column 5 — Unit of Measure (U/M). Indicates the measure used in performing the actual maintenance function. This measure is expressed by a two-character alphabetical abbreviation (e.g., ea, in, pr). If the unit of measure differs from the unit of issue, requisition the lowest unit of issue that will satisfy your requirements.

(Next printed page is E-2)

Section II. EXPENDABLE SUPPLIES AND MATERIALS LIST

(1) Item No.	(2) Level	(3) National Stock Number	(4) Description	(5) Unit of Meas
			Part No. end FSCM	
1	O	6850-00-105-3084	Trichlorotrifluoroethane, Type TF (81348), Cleaning Solvent 16 oz.	OZ
2	O	6850-00-880-7616	Silicone Compound	OZ
3			Deleted	
4	O	8040-00-753-4800	Epoxy	OZ
5	O	8110-01-229-7546	Enamel, Alkyd, Camouflage, MILE-52798A (ME)	QT
6	O	7290-00-985-6849	Cloth, Polishing 13 1/2 X 11 in.	EA
7	O	6850-00-880-7616	Dow Corning No. 4 Silicone Grease, 8 oz. tube	OZ
8	O	6850-00-177-5094	Dow Corning No. 4 Silicone Grease, 2 oz. tube	oz

INDEX

	Paragraph	Page
Additional equipment required	1-12	1-6
Antenna		
Equipment OE-254/GRC	6-3	6-5
Equipment RC-292	6-3	6-5
Homing loop AT-784/PRC	6-4	6-5
Installation:		
AT-271A/PRC	2-6a	2-8
AT-892/PRC-25	2-6b	2-8
AT-984A/G	6-5	6-7
Preventive maintenance and repair	6-5c	6-9
Antijamming	3-7	3-5
Arctic:		
Conditions, operating procedures	3-8	3-5
Operation using Battery, Dry BA-398/U	6-2	6-5
Battery:		
Description, Lithium BA-5598/U	1-12,6-2	1-6,6-5
Description, Magnesium BA-4386/U	1-12,6-2	1-6,6-5
Description, Nickel-Cadmium BB-586/U	1-12,6-2	1-6,6-5
Installation and removal	2-4	2-2
Storage	2-4.1	2-3
Checking unpacked equipment	2-2	2-1
Cleaning	4-3	4-4
Components of Radio Set AN/PRC-77	1-10	1-3
Connector gasket replacement	5-5.1	5-3.1
Connector O-ring, replacement	5-5.1	5-3.1
Control Group AN/GRA-6	6-9	6-20
Controls, indicators and connectors, Receiver-Transmitter		
Radio RT-841/PRC-77	3-1	3-1
Description, general	1-11	1-3
Destruction	1-6	1-2
Dimensions, component	2-1b	2-1
Forms and records	1-3	1-1
Homing operation Antenna, Homing Loop	6-4	6-5
Index, Army Publications & Blank Forms	1-2	1-1
Installation:		
Antenna:		
AT-271A/PRC	2-6a	2-8
AT-892/PRC-25	2-6b	2-8
AT-984A/G	6-5	6-7
Other	2-6c	2-8
Battery	2-4	2-2
Jamming:		
Recognition and identification	3-6	3-5
Antijamming	3-7	3-5
Loudspeaker, electromagnetic LS-549/PRC	6-6	6-9
Maintenance service and inspection Periods (operator)	4-2	4-1
Maintenance, (organizational)	5-3	5-1
Manpack operation	2-5	2-3
Minor components	1-11b	1-3
Operating procedures:	3-4	3-4
Arctic conditions	3-8	3-5

INDEX - Continued

	Paragraph	Page
Operator's maintenance:		
Preventive maintenance checks and services chart	T4-1	4-2
Scope	4-1	4-1
Organizational maintenance:		
Preventive maintenance	5-3	5-1
Preventive maintenance checks and services chart	T5-1	5-2
Scope	5-1	5-1
Oscillator, audio frequency O-574/GRA	6-8	6-13
Pack frame LC-2	6-10	6-22
Presetting channels	3-2	3-1
Preventive maintenance checks and services chart:		
Operator's	4-2	4-2
Organizational	5-3	5-1
purpose and use of Radio Set AN/PRC-77	1-8	1-2
Radio Set Control AN/GSA-7	6-8	6-13
Radio Set Control Group AN/GRA-39	6-7	6-10
Receiver-Transmitter, Radio RT-841/PRC-77:		
Controls, indicators, and connectors	3-1	3-1
Description	1-11a	1-3
Radio/wire integration	6-7b	6-11
Relay procedures	6-1	6-1
Retransmission Cable Kit MK-456/GRC	6-1	6-1
Scope:		
Manual ,	1-1	1-1
Operator's maintenance	4-1	4-1
Organizational maintenance	5-1	5-1
Selecting preset channels	3-3	3-4
Siting	2-3	2-2
Squelch operation:		
Operating procedure	3-4	3-4
Operating conditions	3-10	3-6
Stopping procedure	3-5	3-5
System application	3-11	3-6
Technical characteristics	1-9	1-2
Test sets:		
Radio, AN/PRM-34	5-6	5-4
Power, TS 2609/U	5-7	5-4.1
Tools, materials and test equipment required (organizational maintenance)	5-2	5-1
Troubleshooting:		
Operator's,	4-5	4-5
Organizational	5-4	5-3
Unpacking	2-1	2-1
Visual inspection	4-4	4 5

By Order of the Secretary of the Army:

Official:

JOHN A. WICKHAM, JR.
General, United States Army
Chief of Staff

R.L. DILWORTH
Brigadier General, United States Army
The Adjutant General

DISTRIBUTION:

To be distributed in accordance with DA Form 12-51 literature requirements for AN/PRC-77 and RT-841/PRC-77.

RECOMMENDED CHANGES TO EQUIPMENT TECHNICAL PUBLICATIONS



THEN... JOT DOWN THE DOPE ABOUT IT ON THIS FORM. CAREFULLY TEAR IT OUT. FOLD IT AND DROP IT IN THE MAIL!

SOMETHING WRONG WITH THIS PUBLICATION?

FROM (PRINT YOUR UNIT'S COMPLETE ADDRESS)
 Commander
 Stateside Army Depot
 ATTN: AMSTA-US
 Stateside, N.J. 07703-5007

DATE SENT 10 July 1975

PUBLICATION NUMBER
 TM 11-5840-340-12

PUBLICATION DATE
 23 Jan 74

PUBLICATION TITLE
 Radar Set AN/PRC-76

BE EXACT PIN-POINT WHERE IT IS

PAGE NO	PARA-GRAPH	FIGURE NO	TABLE NO
2-25	2-28		
3-10	3-3		3-1
5-6	5-8		
		FO3	

IN THIS SPACE TELL WHAT IS WRONG AND WHAT SHOULD BE DONE ABOUT IT:

Recommend that the installation antenna alignment procedure be changed throughout to specify a 2° IFF antenna lag rather than 1°.

REASON: Experience has shown that with only a 1° lag, the antenna servo system is too sensitive to wind gusting in excess of 25 knots, and has a tendency to rapidly accelerate and decelerate as it hunts, causing strain to the drive train. Hunting is minimized by adjusting the lag to 2° without degradation of operation.

Item 5, Function column. Change "2 db" to "3db."

REASON: The adjustment procedure for the TRANS POWER FAULT indicator calls for a 3 db (500 watts) adjustment to light the TRANS POWER FAULT indicator.

Add new step f.1 to read, "Replace cover plate removed in step e.1, above."

REASON: To replace the cover plate.

Zone C 3. On J1-2, change "+24 VDC to "+5 VDC."

REASON: This is the output line of the 5 VDC power supply. +24 VDC is the input voltage.

PRINTED NAME GRADE OR TITLE AND TELEPHONE NUMBER
 SSG I. M. DeSpirito 999-1776

SIGN HERE

FILL IN YOUR
UNIT'S ADDRESS

FOLD BACK

DEPARTMENT OF THE ARMY

OFFICIAL BUSINESS
PENALTY FOR PRIVATE USE \$300

SAMPLE

Commander
US Army Communications-Electronics Command
and Fort Monmouth
ATTN: AMSEL-ME-MP
Fort Monmouth, New Jersey 07703-5007

TEAR ALONG PERFORATED

RECOMMENDED CHANGES TO EQUIPMENT TECHNICAL PUBLICATIONS



THEN...JOT DOWN THE DOPE ABOUT IT ON THIS FORM. CAREFULLY TEAR IT OUT, FOLD IT AND DROP IT IN THE MAIL.

SOMETHING WRONG WITH THIS PUBLICATION?

FROM: (PRINT YOUR UNIT'S COMPLETE ADDRESS)

DATE SENT

PUBLICATION NUMBER

TM 11-5820-667-12

PUBLICATION DATE

1 January 1986

PUBLICATION TITLE

Radio Set AN/PRC-77

BE EXACT PIN-POINT WHERE IT IS

PAGE NO.

PARA-GRAPH

FIGURE NO.

TABLE NO.

IN THIS SPACE TELL WHAT IS WRONG AND WHAT SHOULD BE DONE ABOUT IT:

REFORMATED LINE

TEAR AL

PRINTED NAME GRADE OR TITLE AND TELEPHONE NUMBER

SIGN HERE

DA FORM 2028-2
1 JUL 79

PREVIOUS EDITIONS ARE OBSOLETE

P.S.--IF YOUR OUTFIT WANTS TO KNOW ABOUT YOUR RECOMMENDATION MAKE A CARBON COPE OF THIS AND GIVE IT TO YOUR HEADQUARTERS.

FILL IN YOUR
UNIT'S ADDRESS

FOLD BACK

DEPARTMENT OF THE ARMY

OFFICIAL BUSINESS
PENALTY FOR PRIVATE USE \$300

Commander
US Army Communications-Electronics Command
and Fort Monmouth
ATTN: AMSEL-ME-MP
Fort Monmouth, New Jersey 07703-5007

TEAR ALONG PERFORATED

RECOMMENDED CHANGES TO EQUIPMENT TECHNICAL PUBLICATIONS



THEN...JOT DOWN THE DOPE ABOUT IT ON THIS FORM. CAREFULLY TEAR IT OUT, FOLD IT AND DROP IT IN THE MAIL.

SOMETHING WRONG WITH THIS PUBLICATION?

FROM: (PRINT YOUR UNIT'S COMPLETE ADDRESS)

DATE SENT

PUBLICATION NUMBER

TM 11-5820-667-12

PUBLICATION DATE

1 January 1986

PUBLICATION TITLE

Radio Set AN/PRC-77

BE EXACT PIN-POINT WHERE IT IS

PAGE NO.

PARA-GRAPH

FIGURE NO.

TABLE NO.

IN THIS SPACE TELL WHAT IS WRONG AND WHAT SHOULD BE DONE ABOUT IT:

PERFORATED LINE

TEAR ALONG

PRINTED NAME GRADE OR TITLE AND TELEPHONE NUMBER

SIGN HERE

DA FORM 2028-2
JUL 79

PREVIOUS EDITIONS ARE OBSOLETE

P.S.--IF YOUR OUTFIT WANTS TO KNOW ABOUT YOUR RECOMMENDATION MAKE A CARBON COPE OF THIS AND GIVE IT TO YOUR HEADQUARTERS.

FILL IN YOUR
UNIT'S ADDRESS

FOLD BACK

DEPARTMENT OF THE ARMY

OFFICIAL BUSINESS
PENALTY FOR PRIVATE USE \$300

Commander
US Army Communications-Electronics Command
and Fort Monmouth
ATTN: AMSEL-ME-MP
Fort Monmouth, New Jersey 07703-5007

TEAR ALONG PERFORATED

RECOMMENDED CHANGES TO EQUIPMENT TECHNICAL PUBLICATIONS



THEN...JOT-DOWN THE DOPE ABOUT IT ON THIS FORM. CAREFULLY TEAR IT OUT, FOLD IT AND DROP IT IN THE MAIL.

SOMETHING WRONG WITH THIS PUBLICATION?

FROM: (PRINT YOUR UNIT'S COMPLETE ADDRESS)

DATE SENT

PUBLICATION NUMBER
TM 11-5820-667-12

PUBLICATION DATE
1 January 1986

PUBLICATION TITLE
Radio Set AN/PRC-77

BE EXACT PIN-POINT WHERE IT IS

PAGE NO.	PARA-GRAPH	FIGURE NO.	TABLE NO.
----------	------------	------------	-----------

IN THIS SPACE TELL WHAT IS WRONG AND WHAT SHOULD BE DONE ABOUT IT:

FORATED LINE

TEAR AL

PRINTED NAME GRADE OR TITLE AND TELEPHONE NUMBER

SIGN HERE

FILL IN YOUR
UNIT'S ADDRESS

FOLD BACK

DEPARTMENT OF THE ARMY

OFFICIAL BUSINESS
PENALTY FOR PRIVATE USE \$300

Commander
US Army Communications-Electronics Command
and Fort Monmouth
ATTN: AMSEL-ME-MP
Fort Monmouth, New Jersey 07703-5007

TEAR ALONG PERFORATED

